



ITERATIVE JUDGMENT AGGREGATION

MARIJA SLAVKOVİK & WOJCIECH JAMROGA

University of Bergen, Norway & Polish Academy of Sciences

Voting

Voting



Results in full >

Leave
51.9%
17,410,742 VOTES

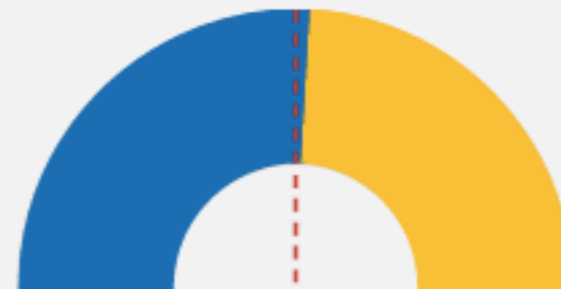

Remain
48.1%
16,141,241 VOTES

LATEST

Pound drops to lowest levels since 1985.

|| < 2/2 >

Judgment aggregation

$$(\varphi_1 \wedge \varphi_2 \wedge \varphi_3) \leftrightarrow r$$

free movement (φ_1) subsidies (φ_2) benefits (φ_3) | remain (r)

Judgment aggregation

$$(\varphi_1 \wedge \varphi_2 \wedge \varphi_3) \leftrightarrow r$$

Voters	free movement (φ_1)	subsidies (φ_2)	benefits (φ_3)	remain (r)
32%	yes	yes	no	no
39%	yes	no	yes	no
10%	no	no	no	no
19%	no	yes	yes	no
Majority	yes	yes	yes	no

Judgment aggregation

$$(\varphi_1 \wedge \varphi_2 \wedge \varphi_3) \leftrightarrow r$$

Voters	free movement (φ_1)	subsidies (φ_2)	benefits (φ_3)	remain (r)
32%	yes	yes	no	no
39%	yes	no	yes	no
10%	no	no	no	no
19%	no	yes	yes	no
Majority	yes	yes	yes	no
winner 1	yes	no	yes	no
winner 2	yes	yes	yes	yes

Judgment aggregation

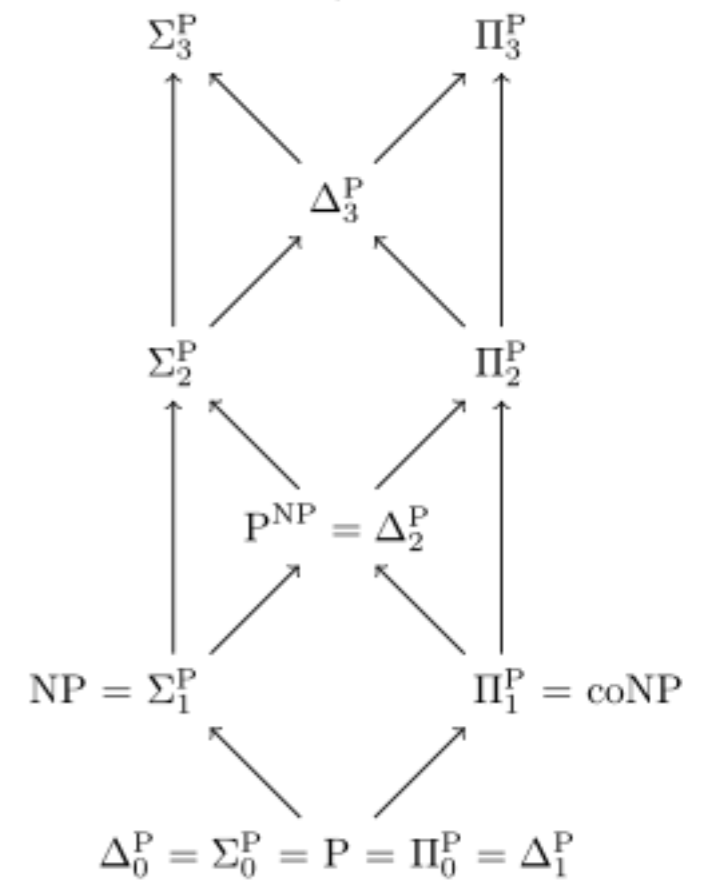

$$(\varphi_1 \wedge \varphi_2 \wedge \varphi_3) \leftrightarrow r$$

Voters	free movement (φ_1)	subsidies (φ_2)	benefits (φ_3)	remain (r)
32%	yes	yes	no	no
39%	yes	no	yes	no
10%	no	no	no	no
19%	no	yes	yes	no
Majority	yes	yes	yes	no
winner 1	yes	no	yes	no
winner 2	yes	yes	yes	yes

Judgment aggregation

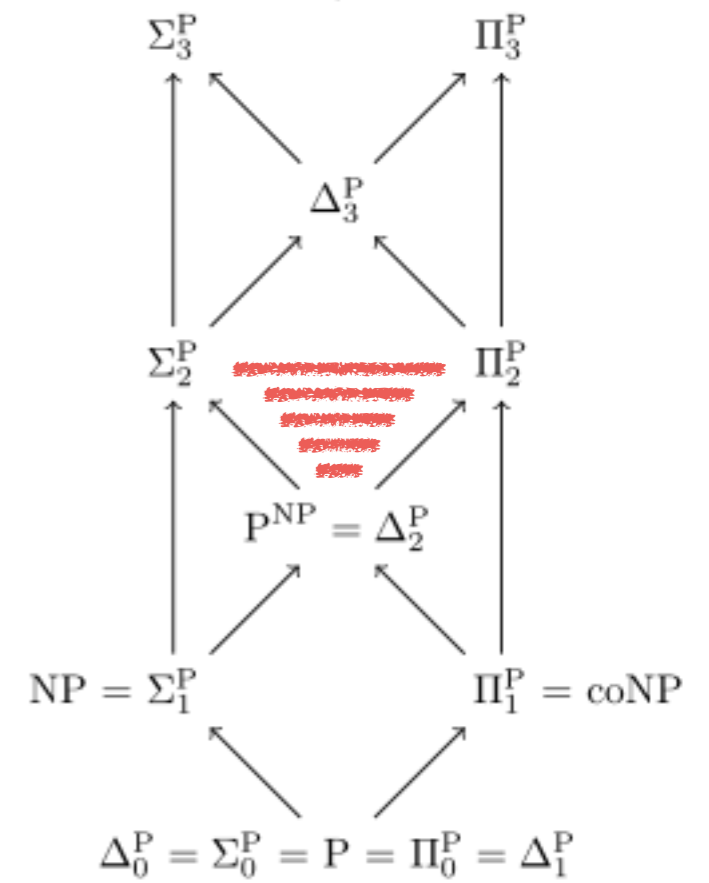

$$(\varphi_1 \wedge \varphi_2 \wedge \varphi_3) \leftrightarrow r$$

Voters	free movement (φ_1)	subsidies (φ_2)	benefits (φ_3)	remain (r)
32%	yes	yes	no	no
39%	yes	no	yes	no
10%	no	no	no	no
19%	no	yes	yes	no
Majority	yes	yes	yes	no
winner 1	yes	no	yes	no
winner 2	yes	yes	yes	yes

Creating room for compromise

Creating room for compromise

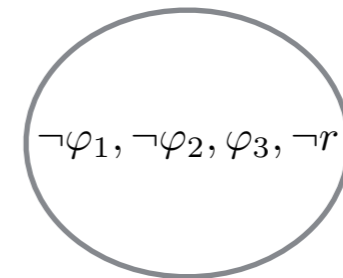
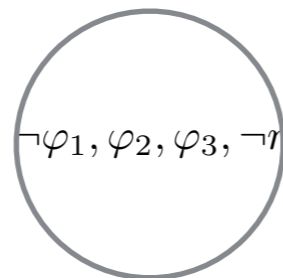
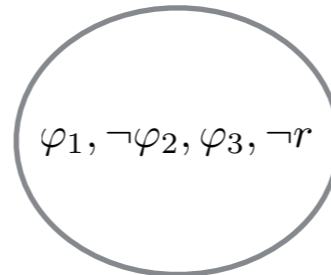
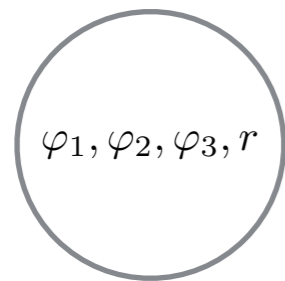

Creating room for compromise

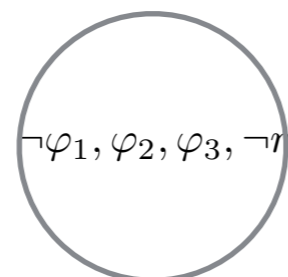
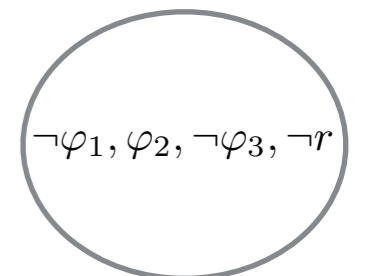
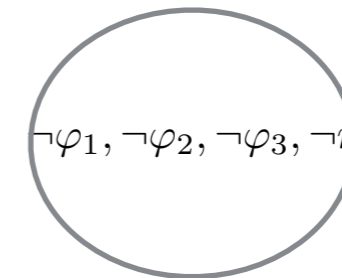
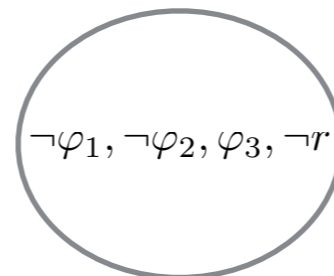
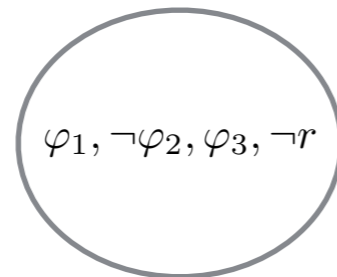
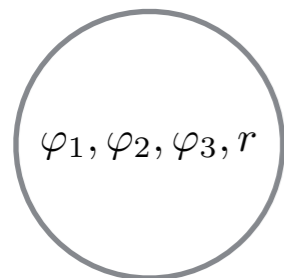
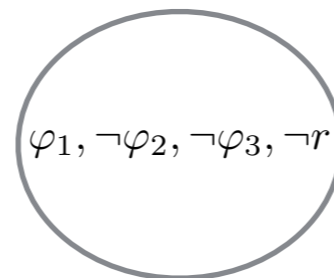
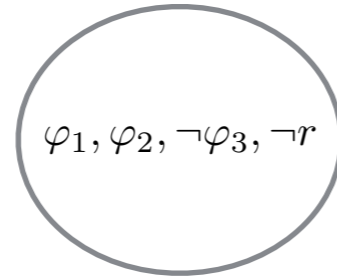

Creating room for compromise

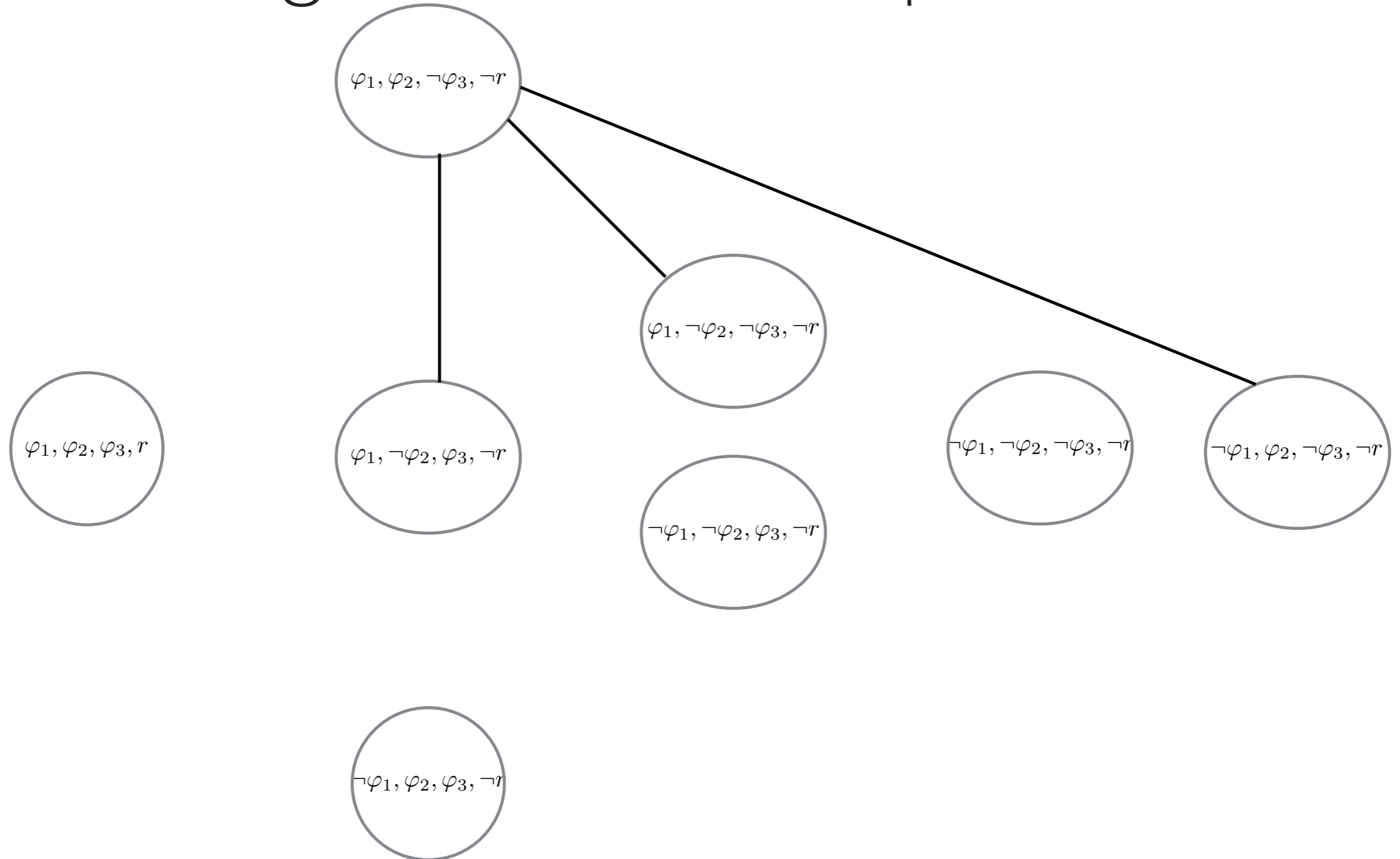

Creating room for compromise

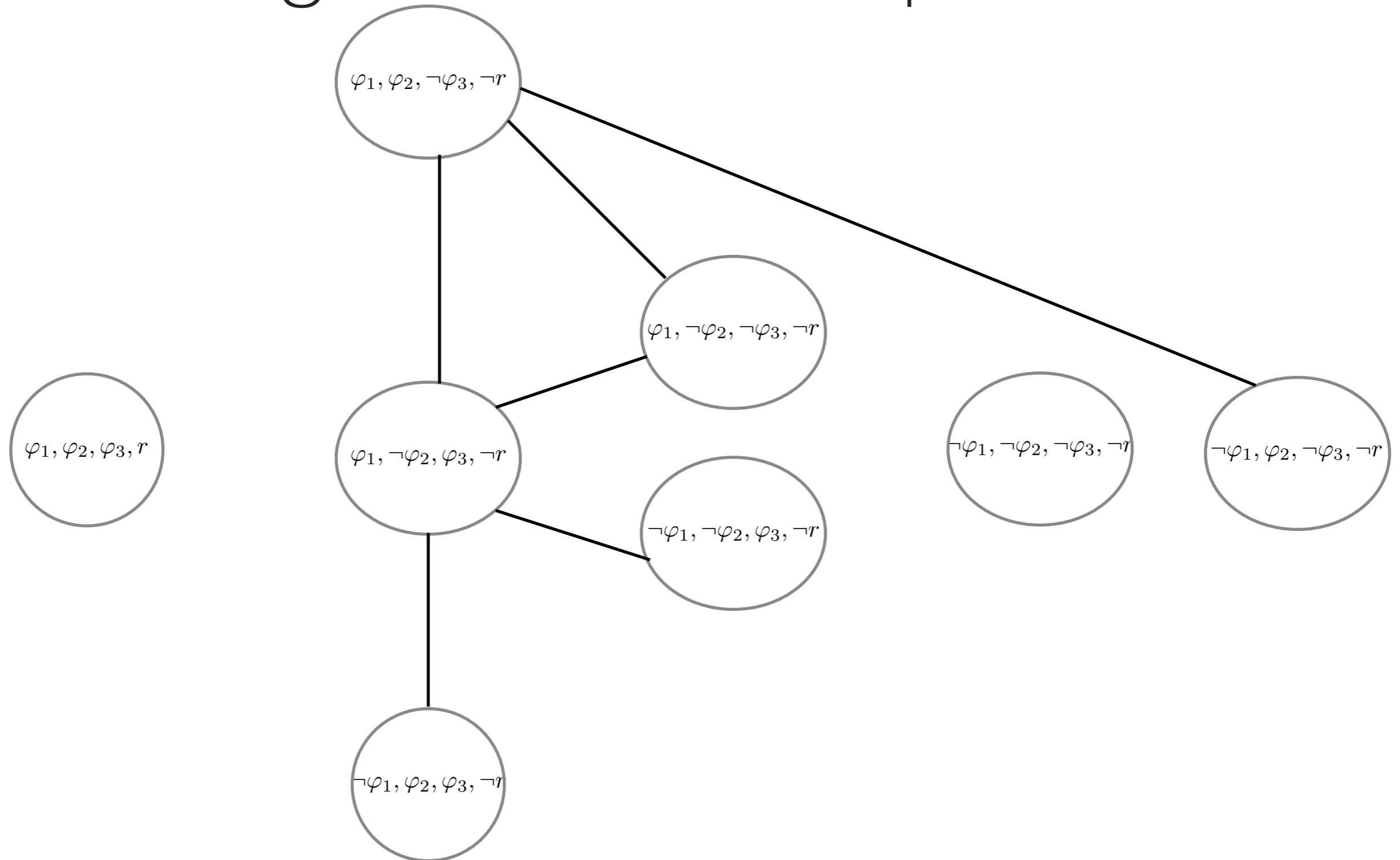

Creating room for compromise

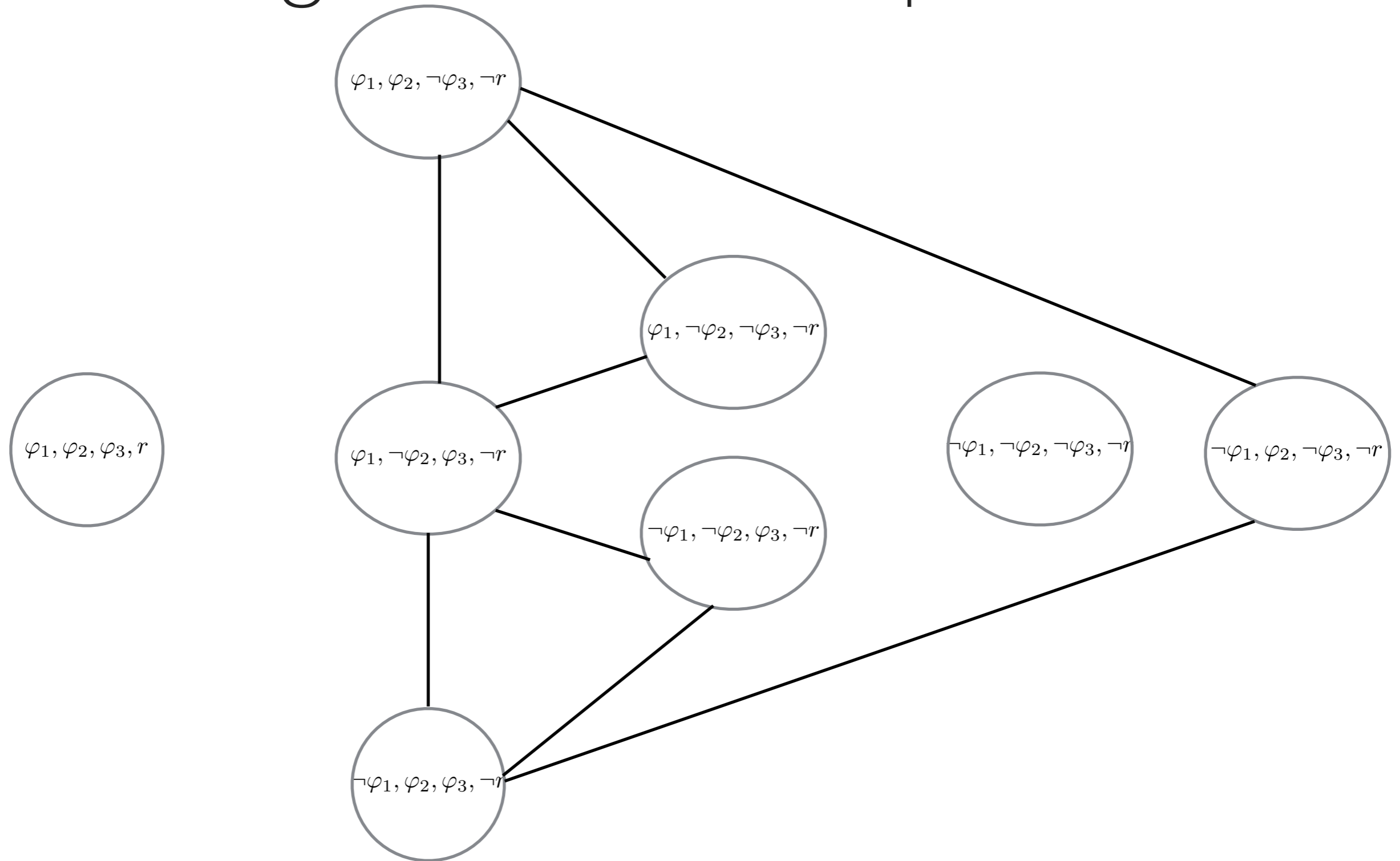

Creating room for compromise

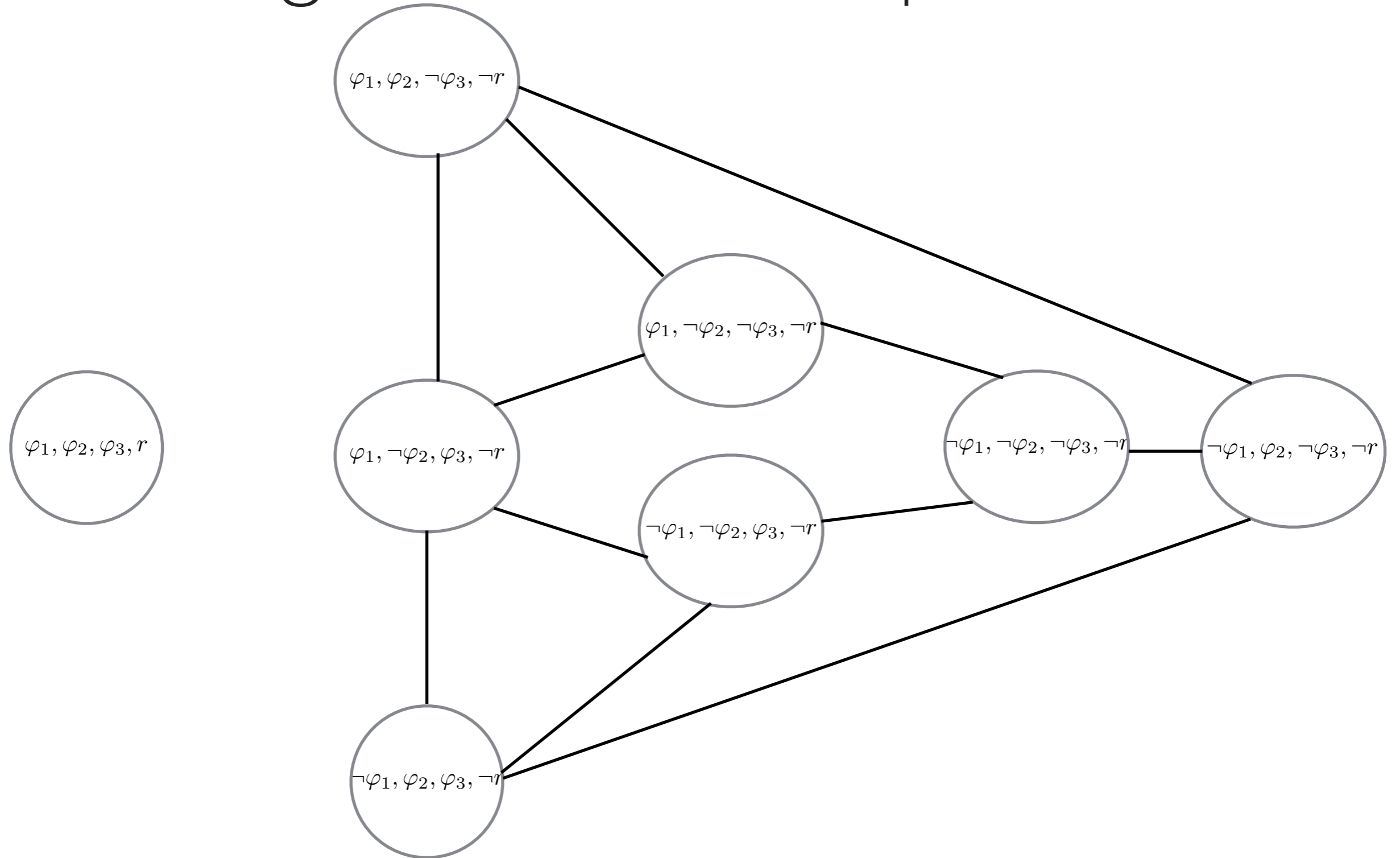

Creating room for compromise

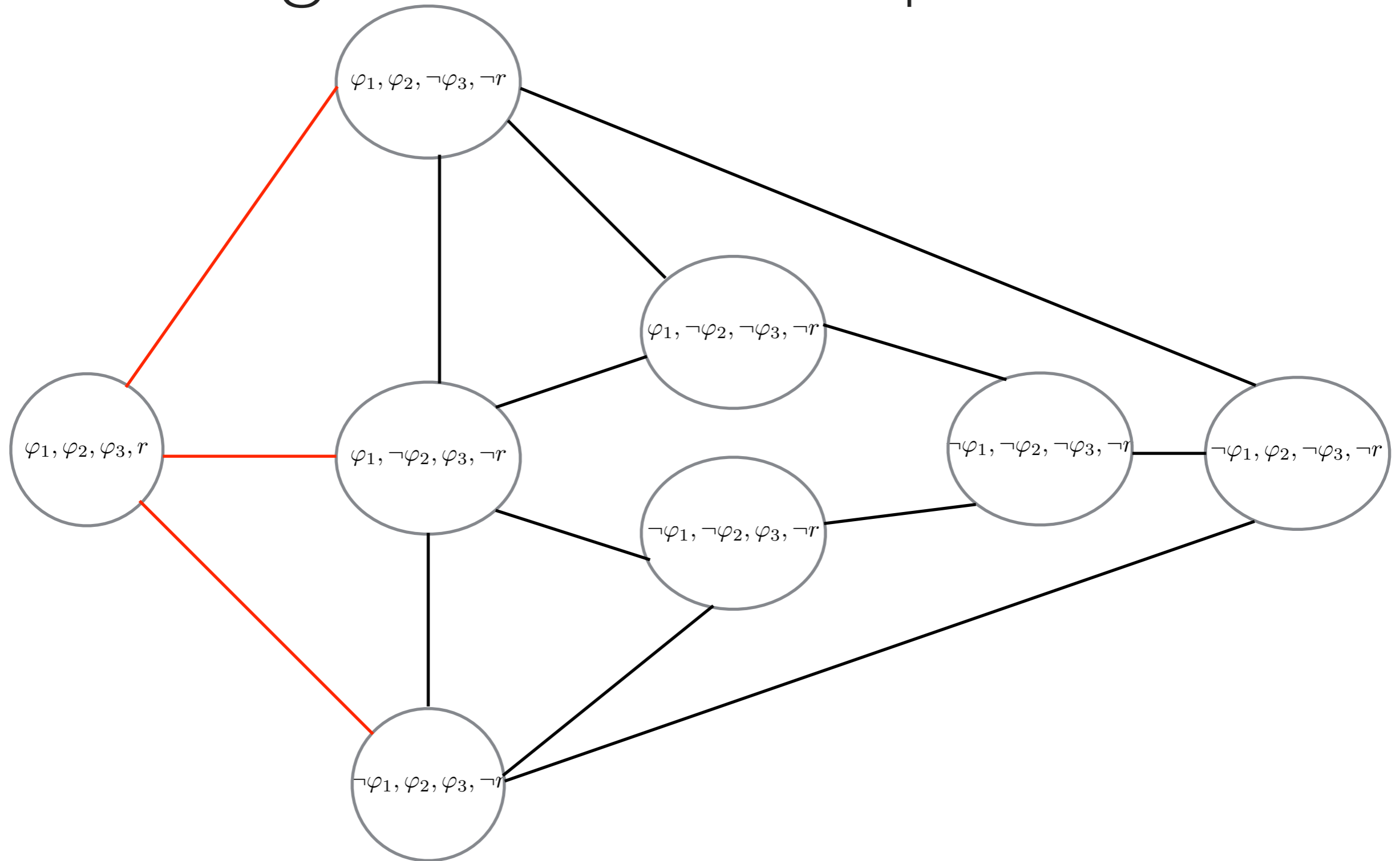

Creating room for compromise

Geodesic agenda graph

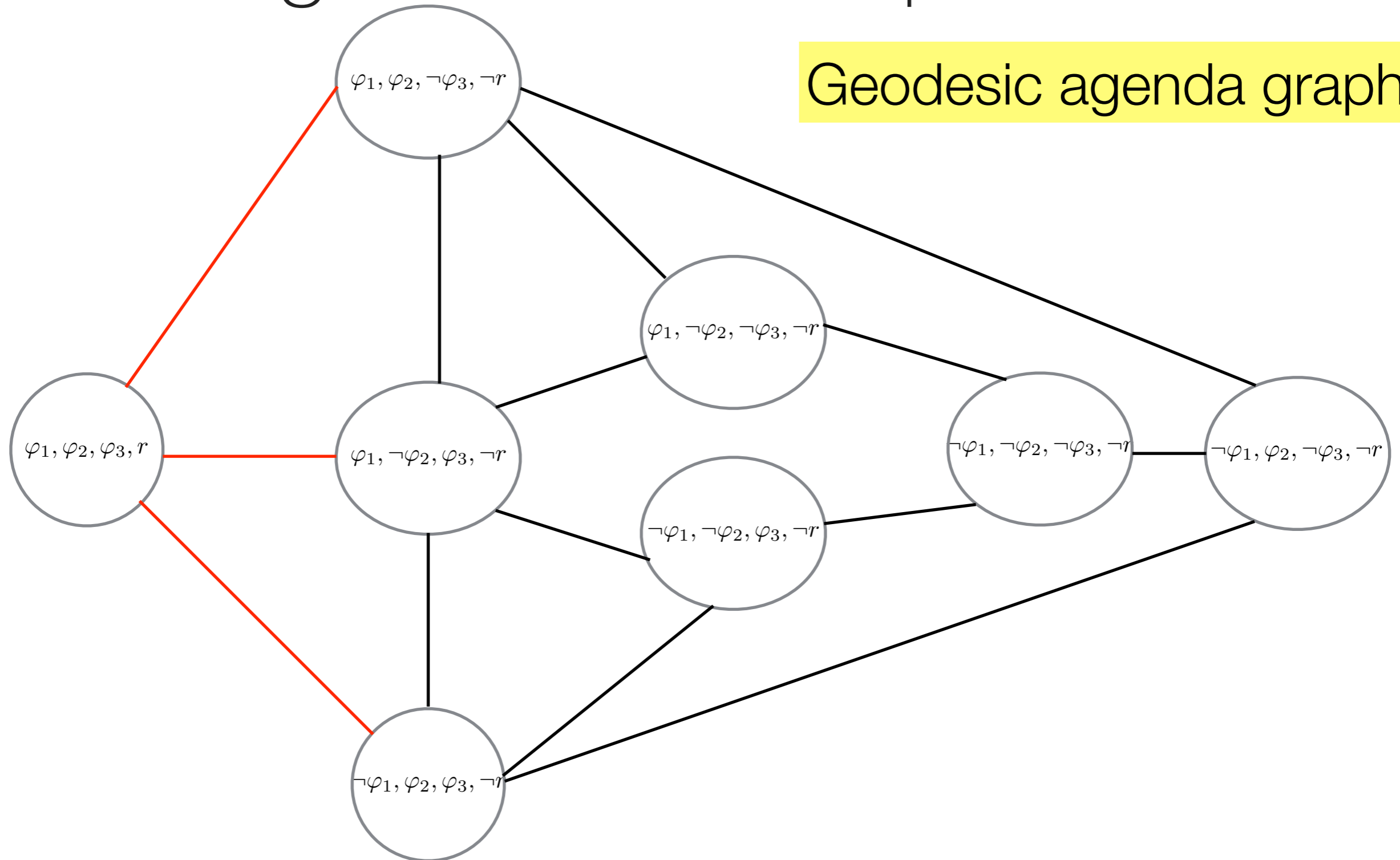

Creating room for compromise

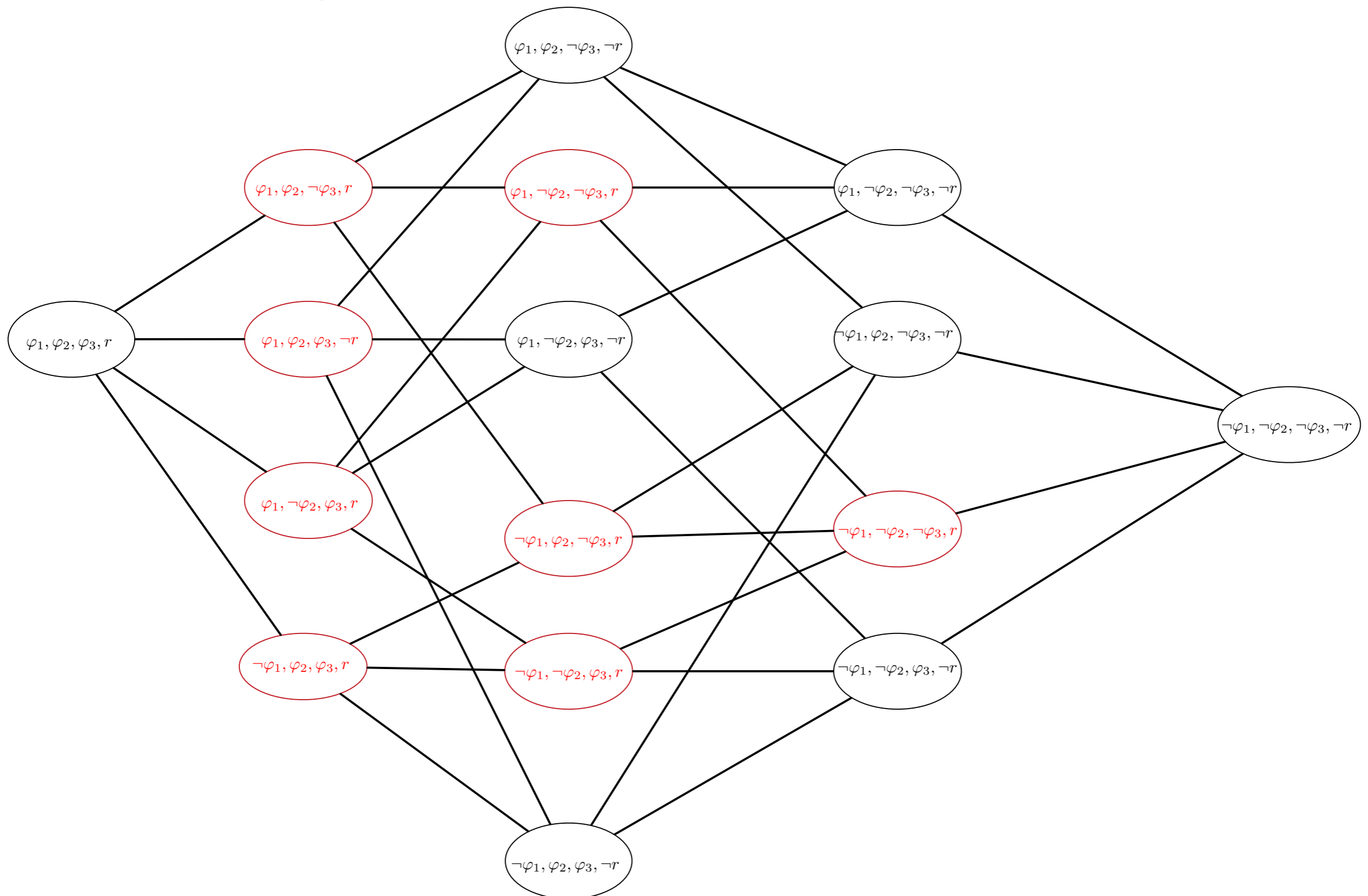

Creating room for compromise

Hamming agenda graph

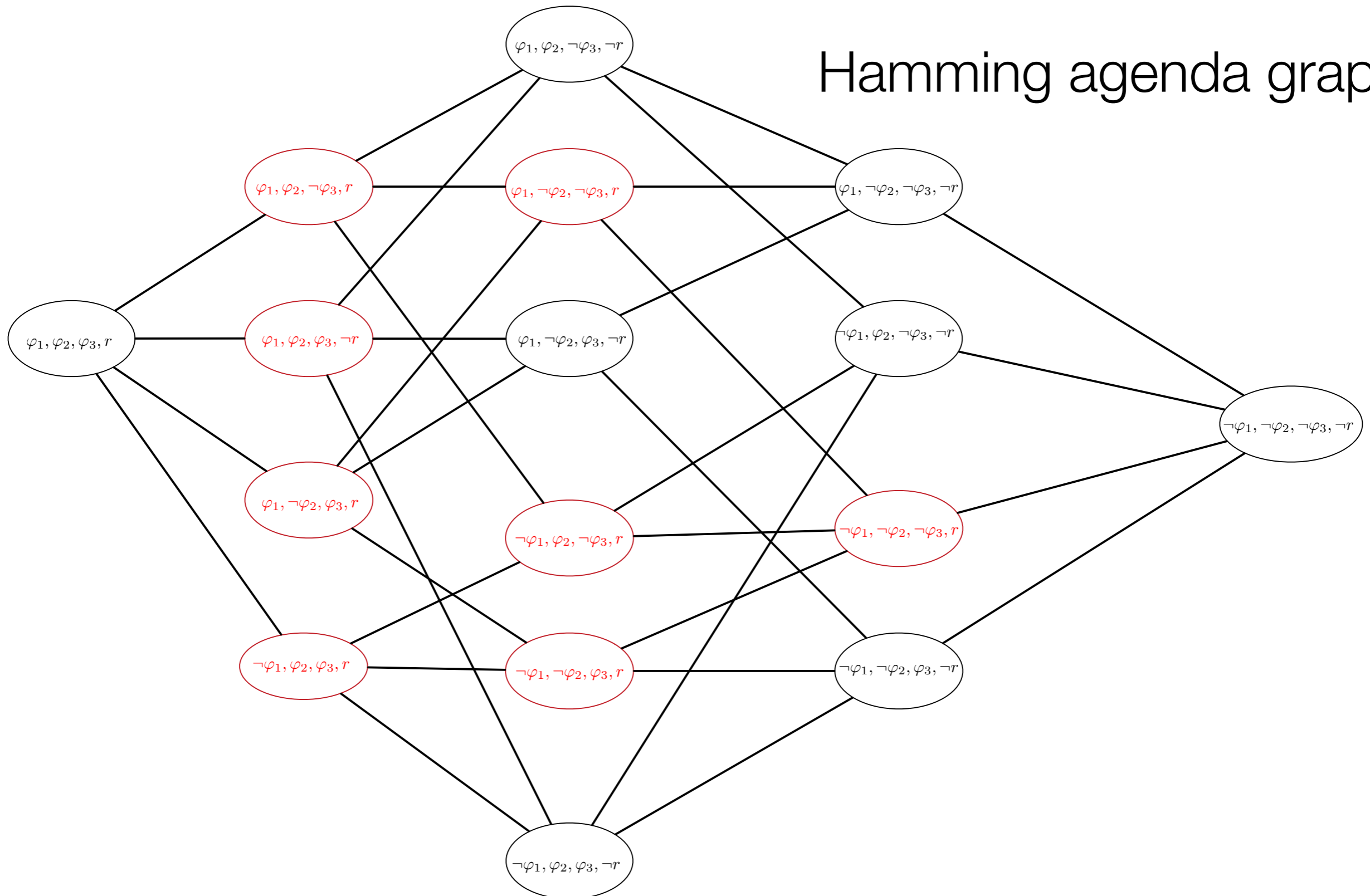

Creating room for compromise

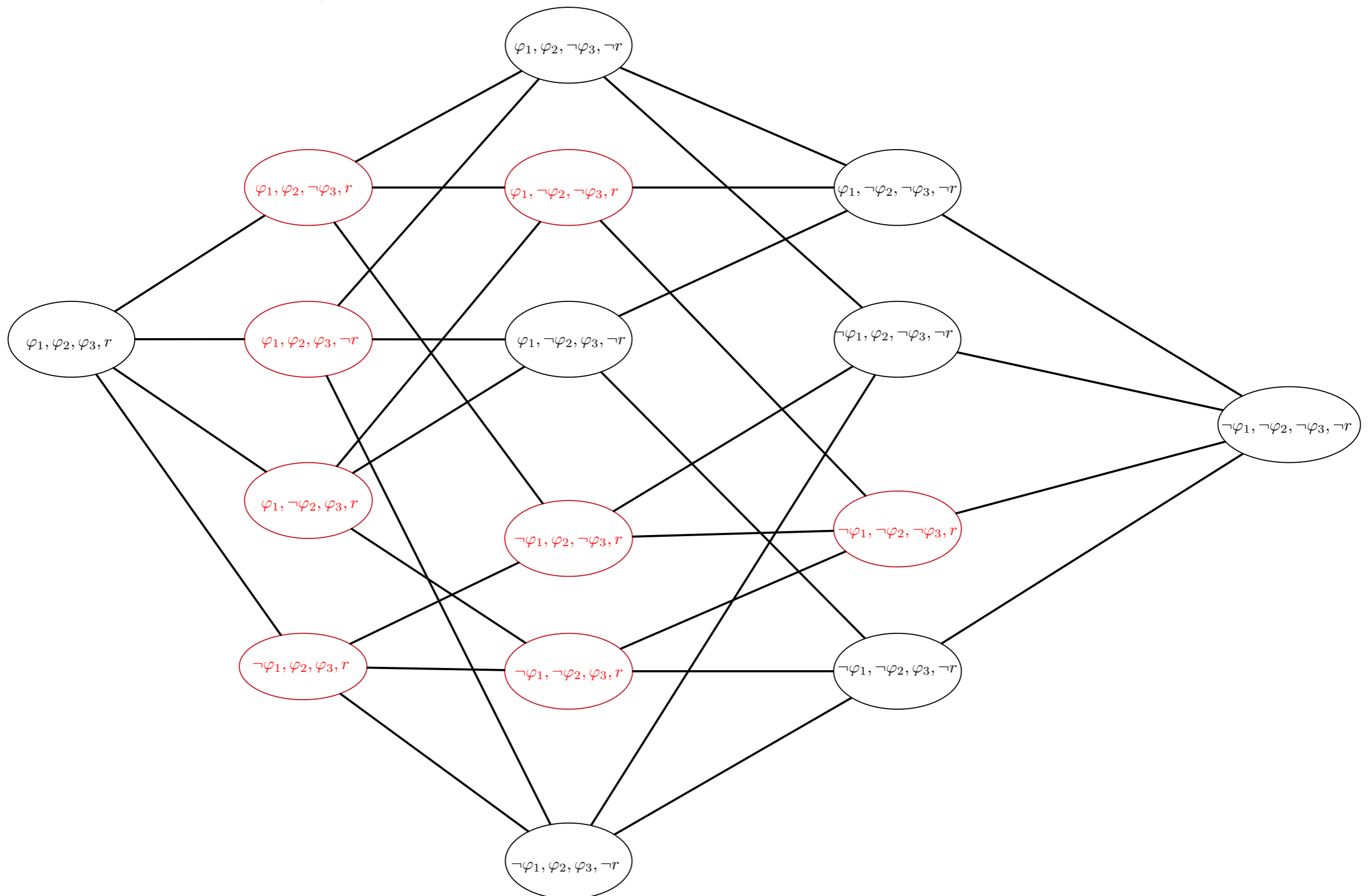

The algorithm



The algorithm

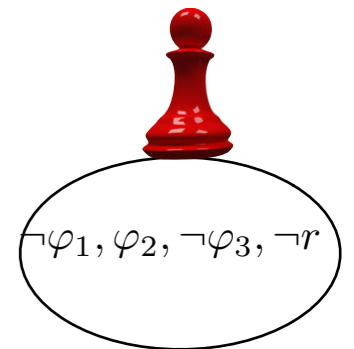
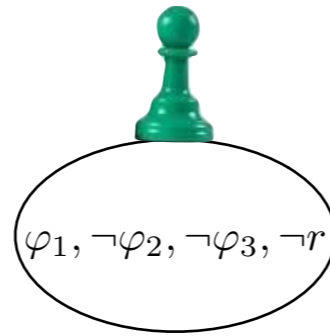

The algorithm

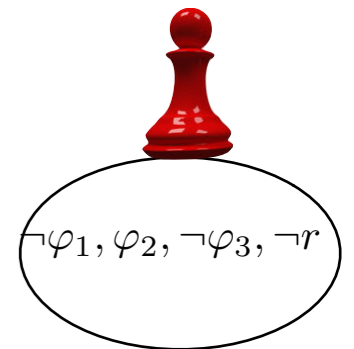
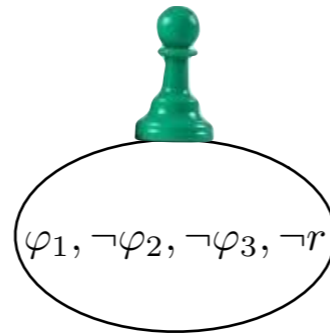

The algorithm

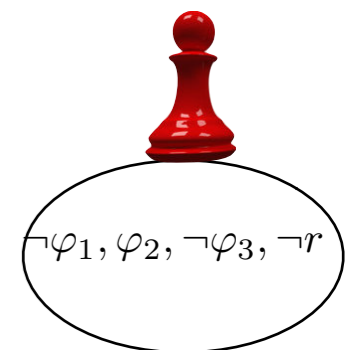
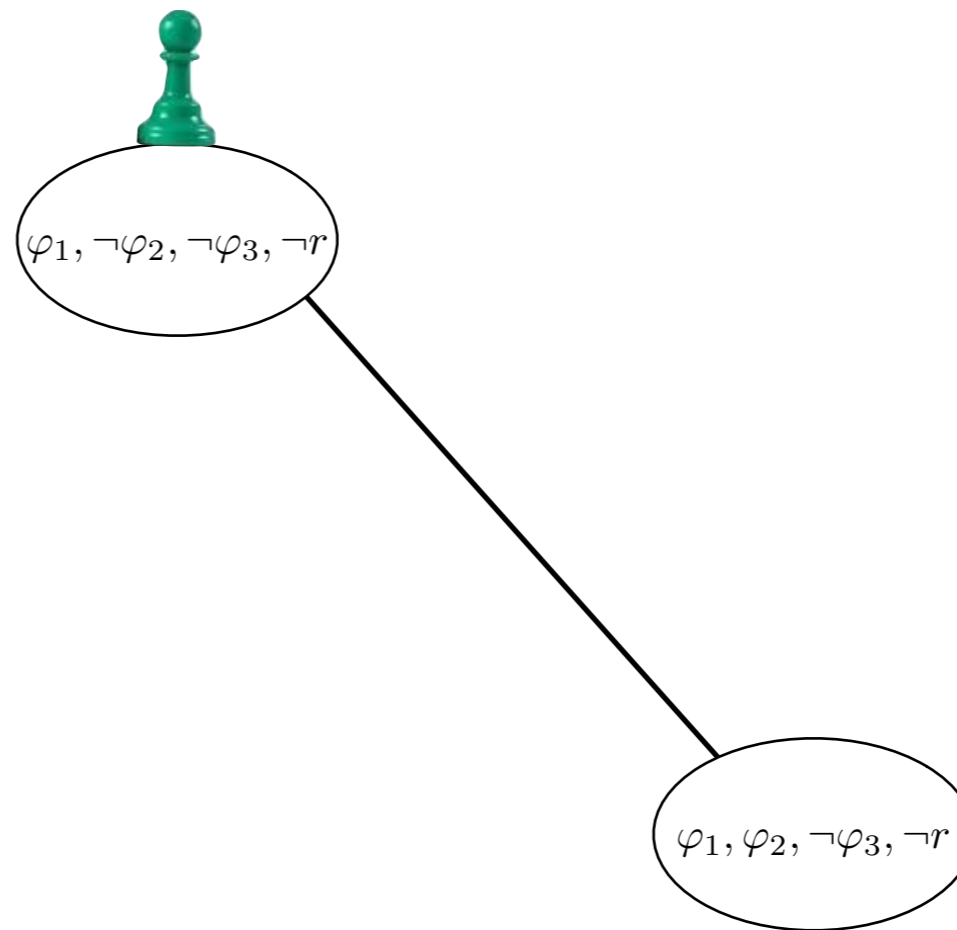

The algorithm

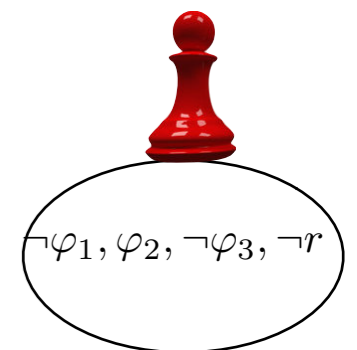
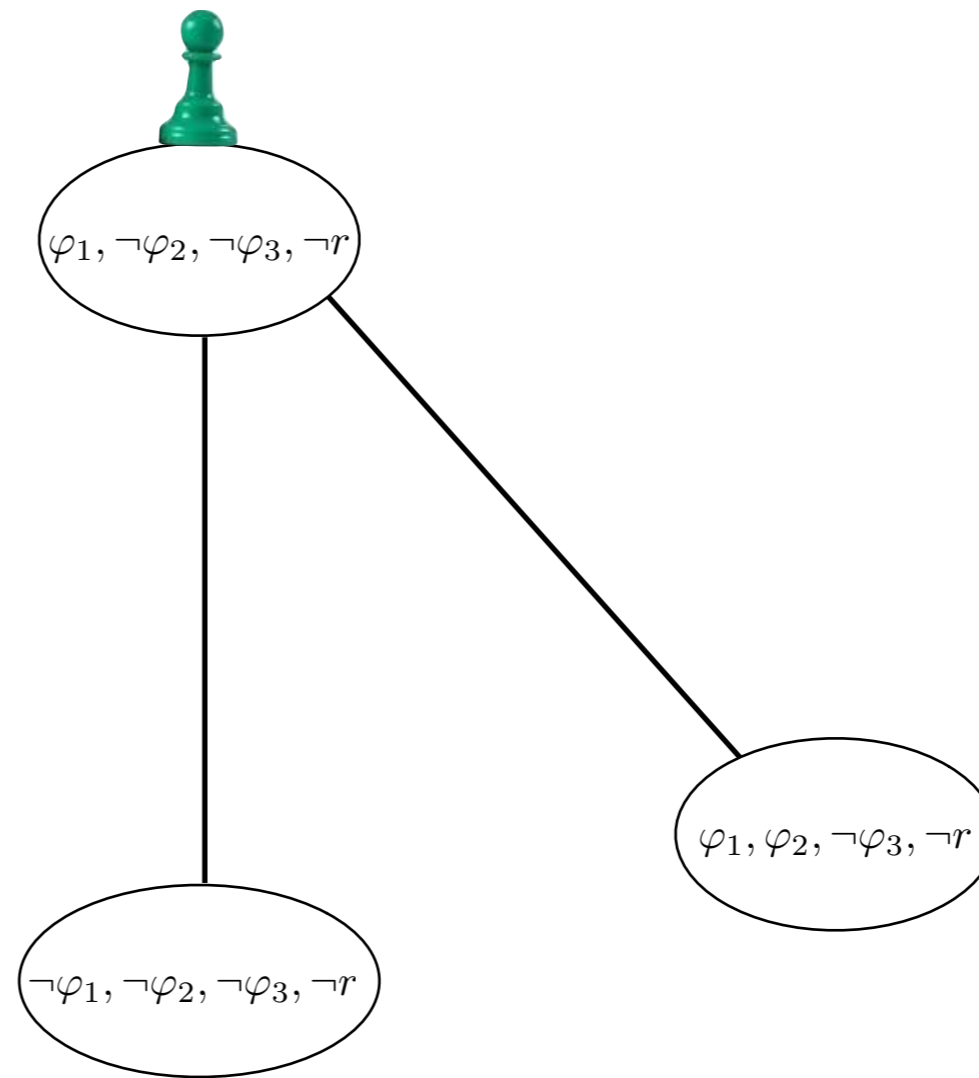

The algorithm

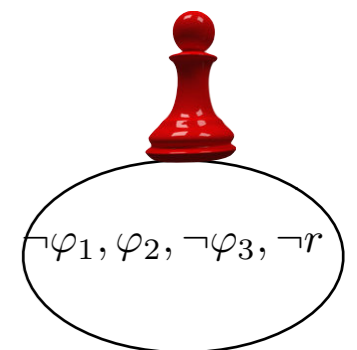
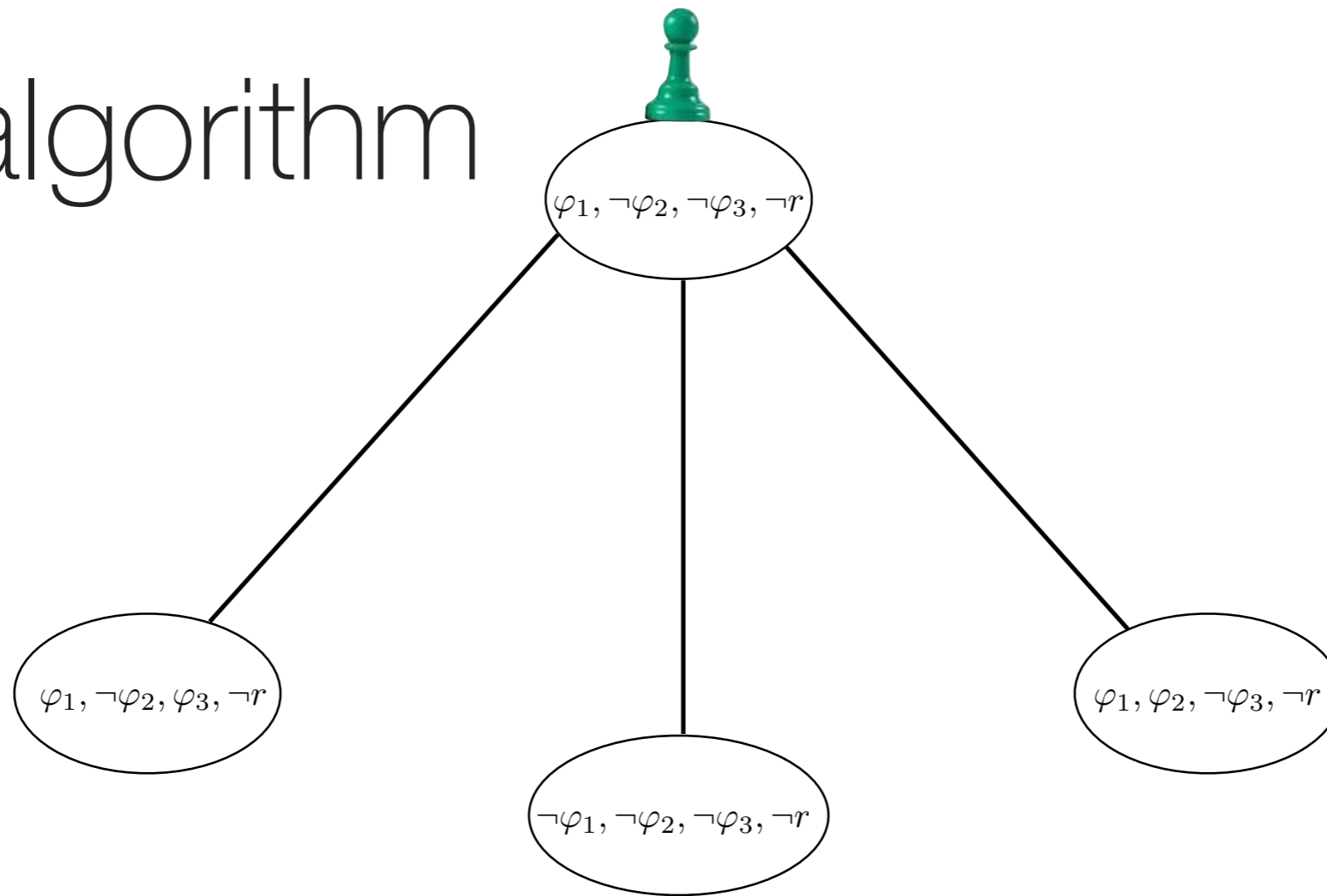

The algorithm

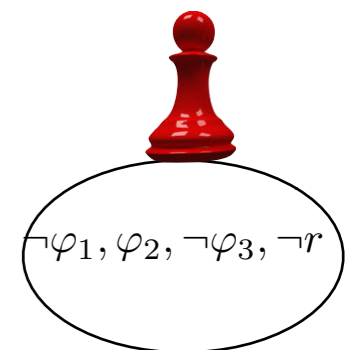
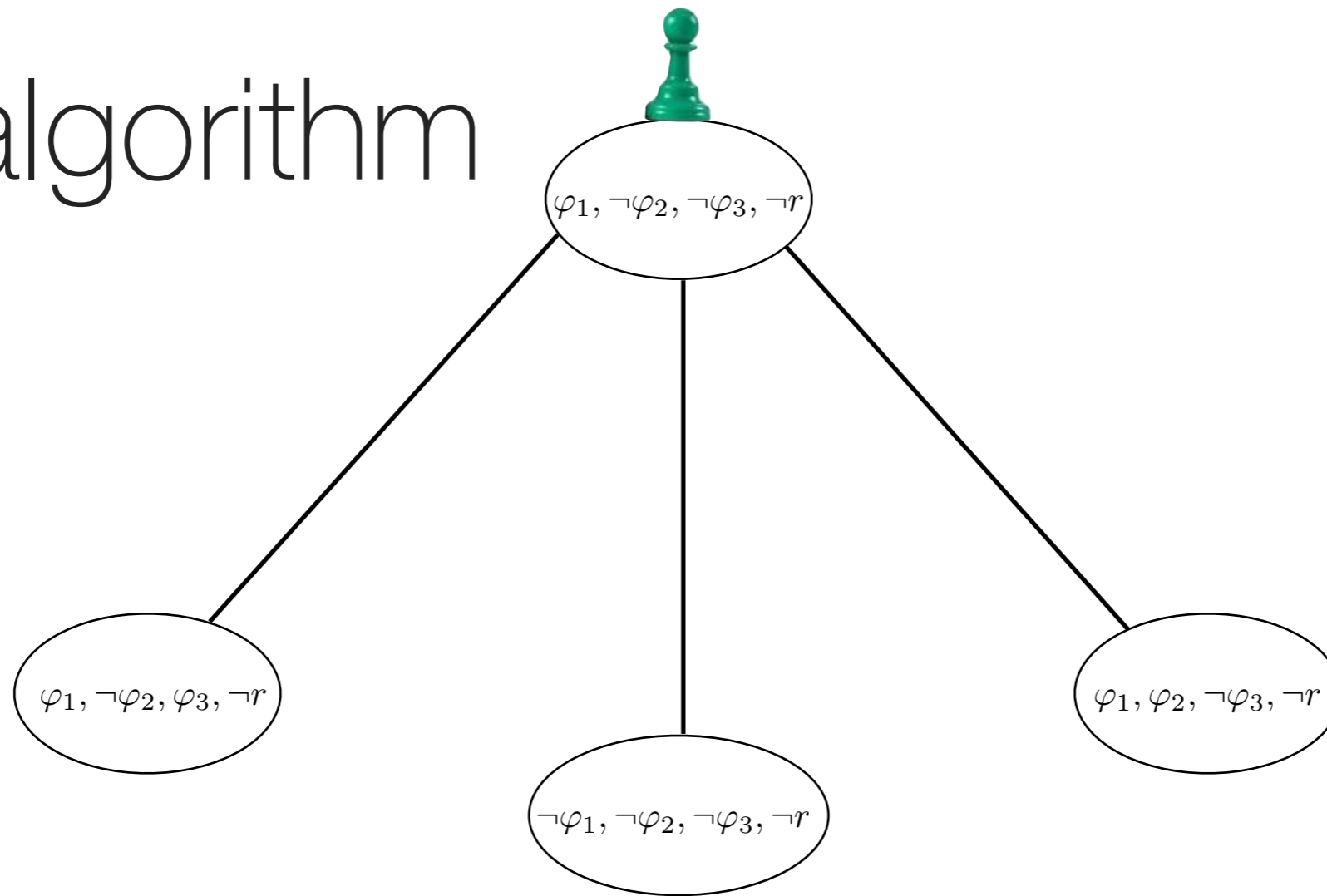

The algorithm

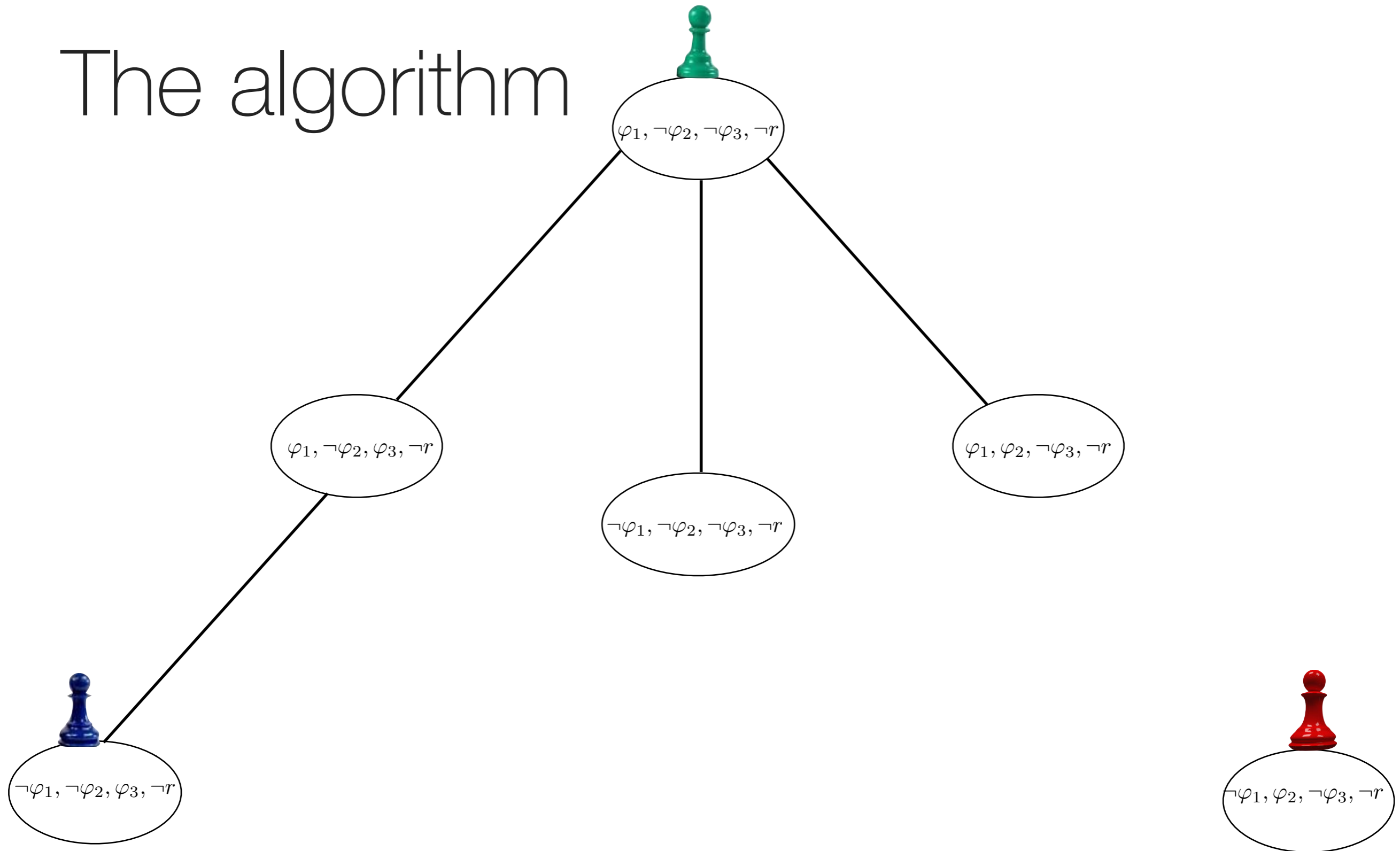

The algorithm

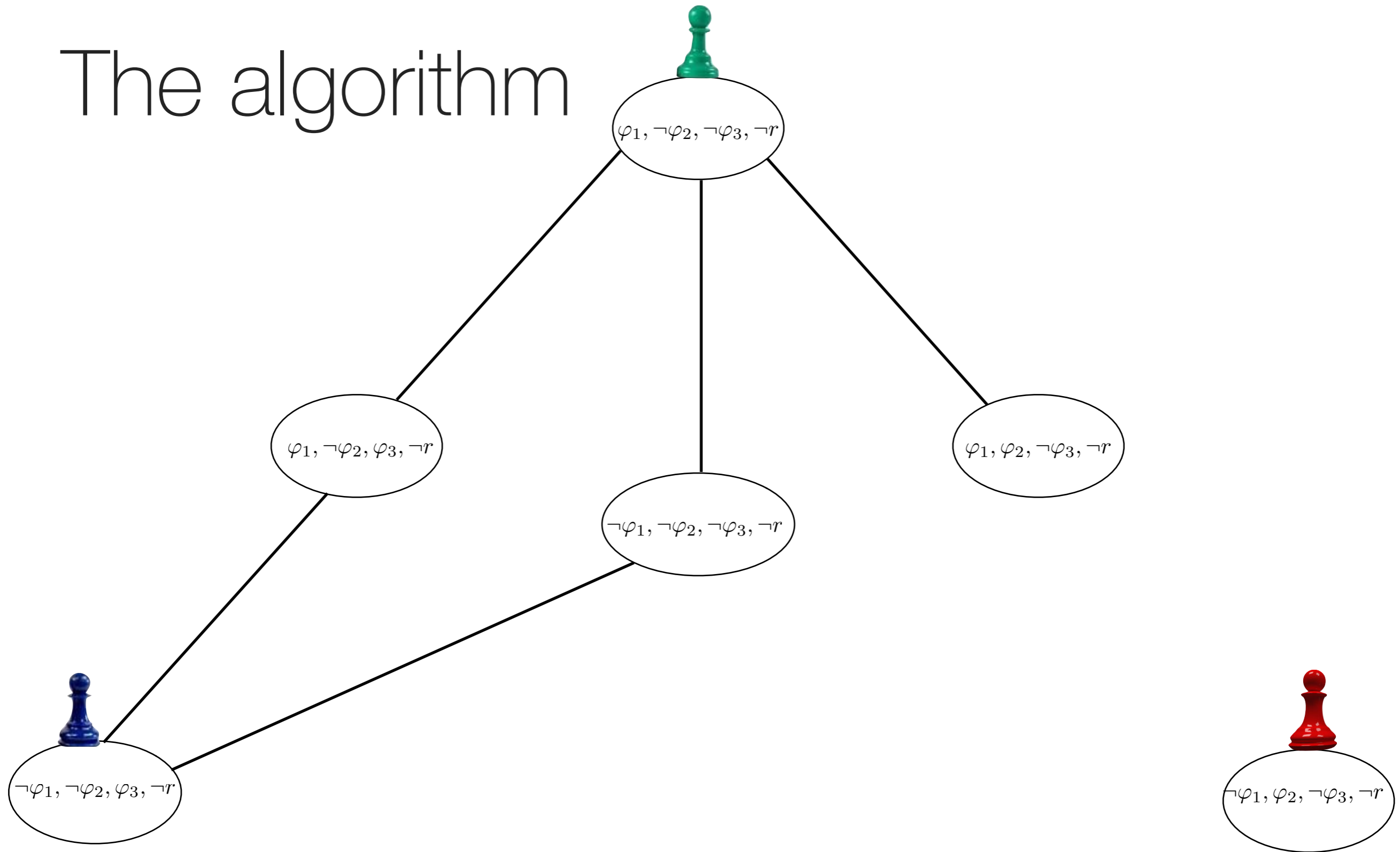

The algorithm

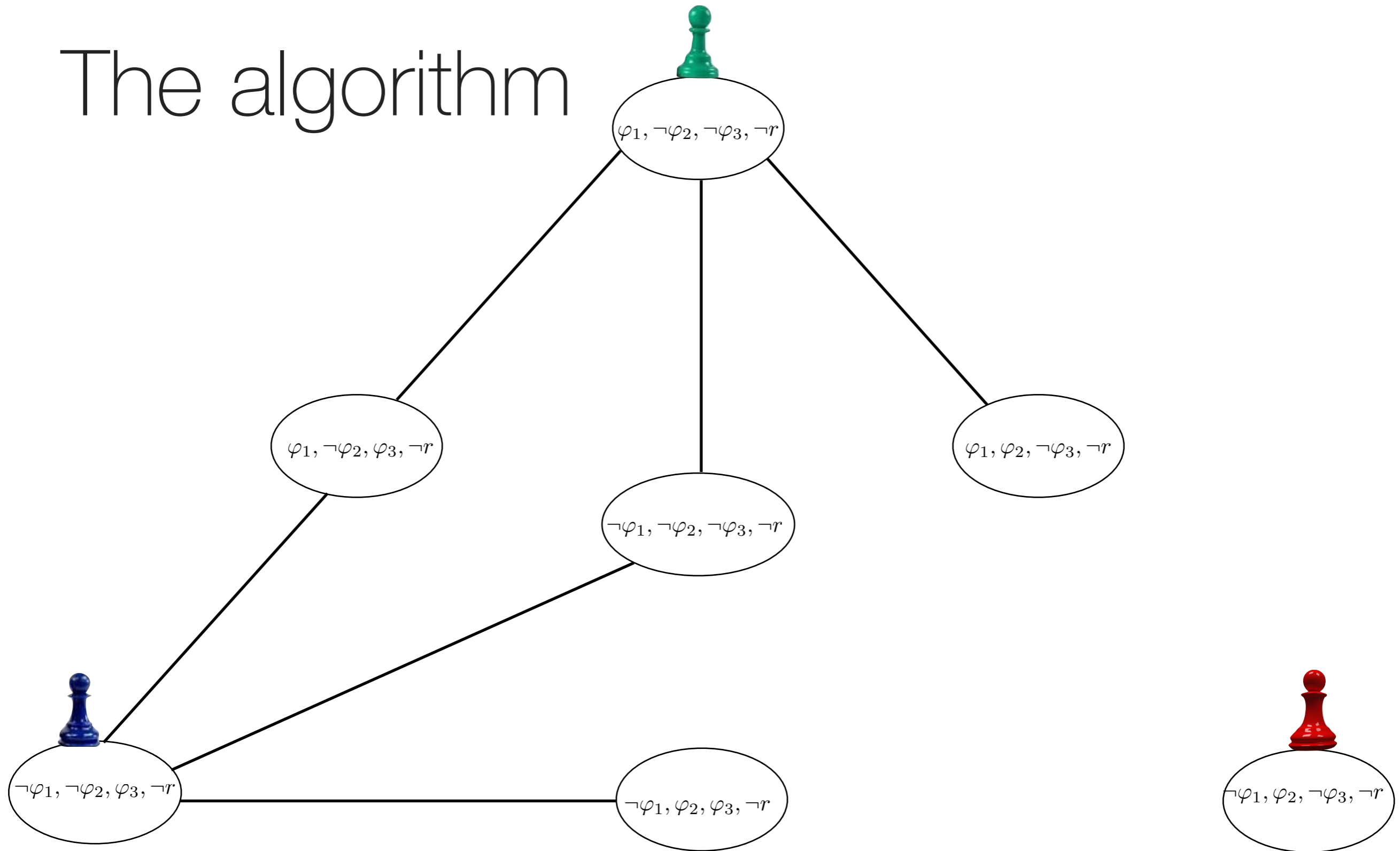

The algorithm

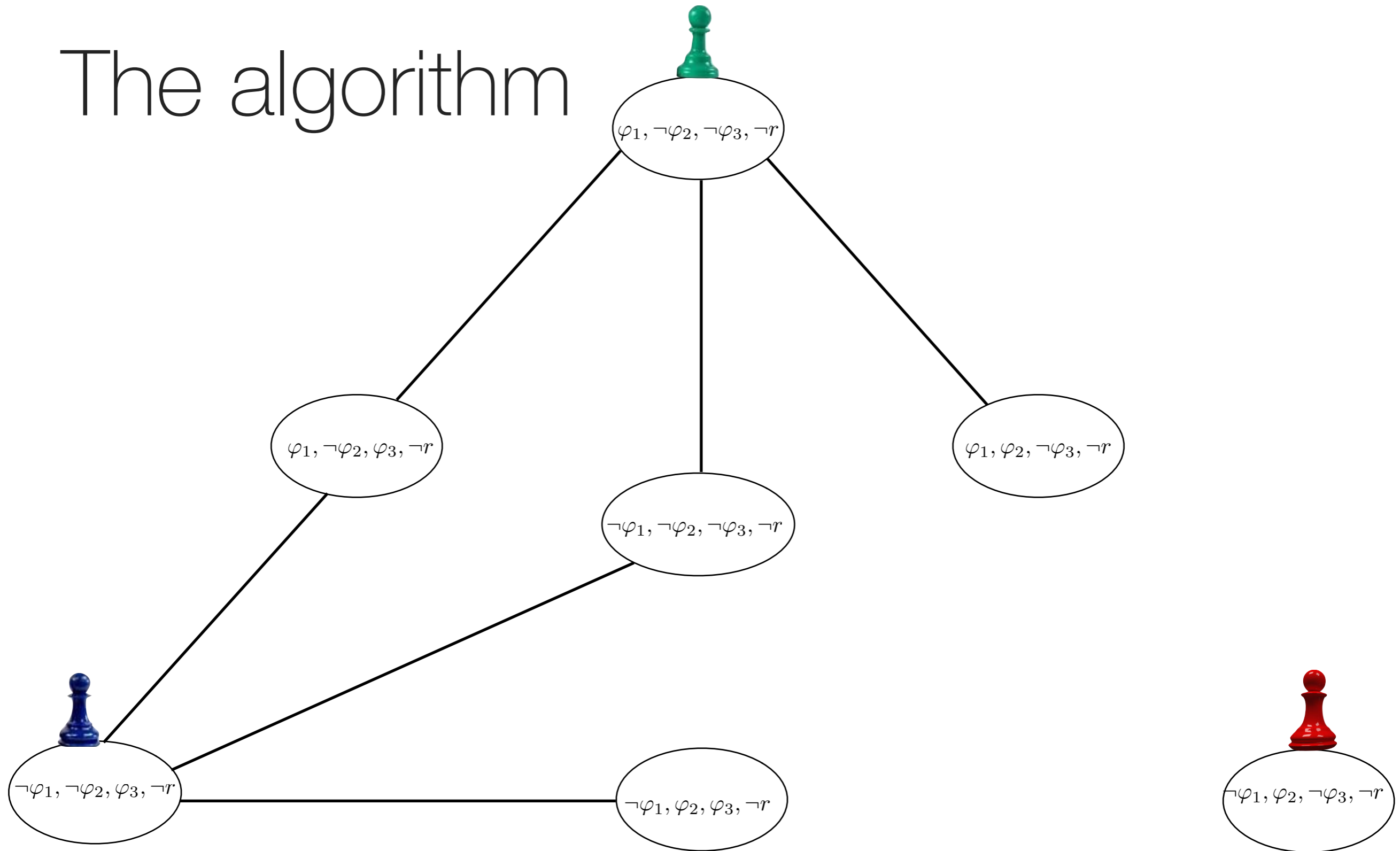

The algorithm

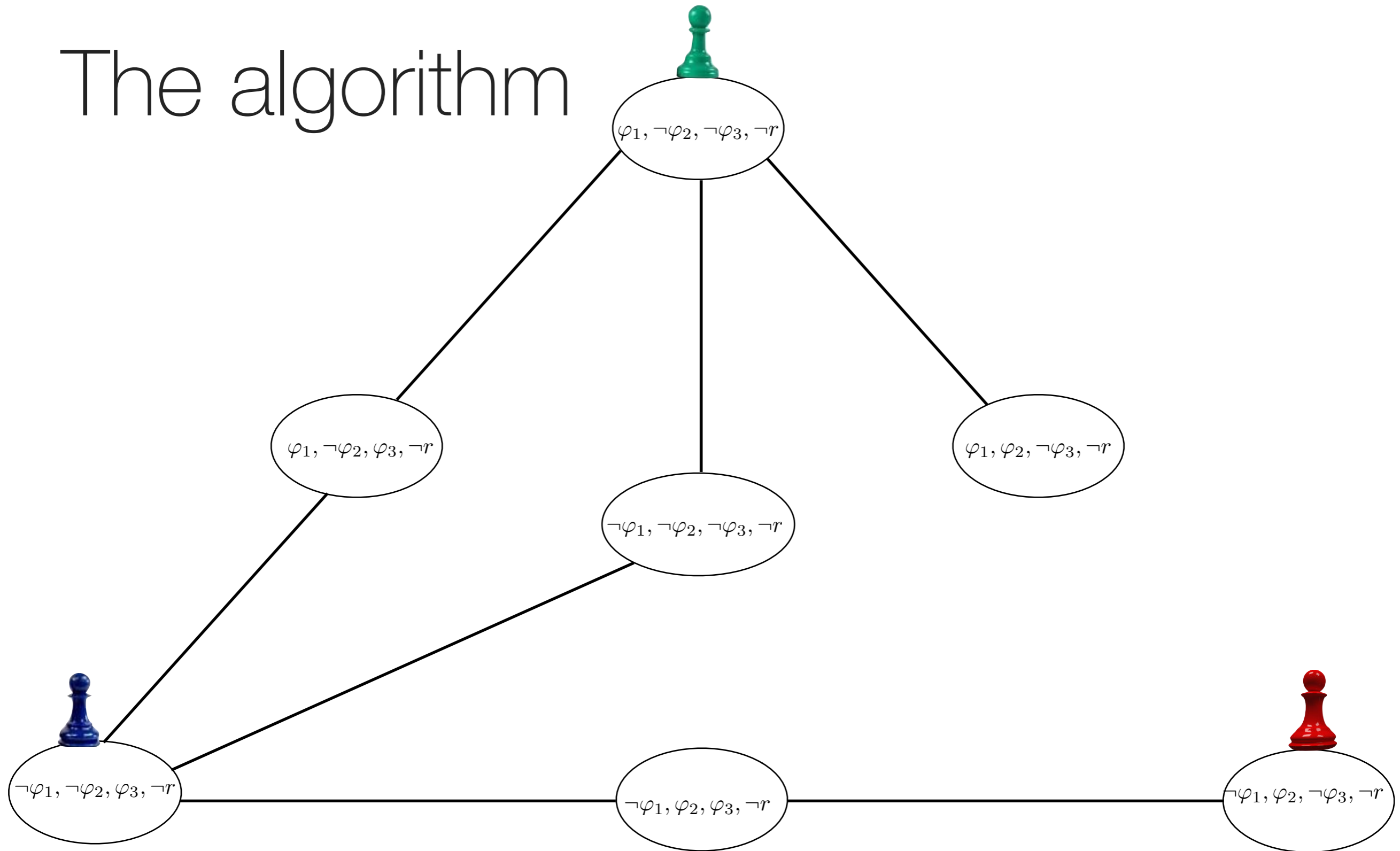

The algorithm

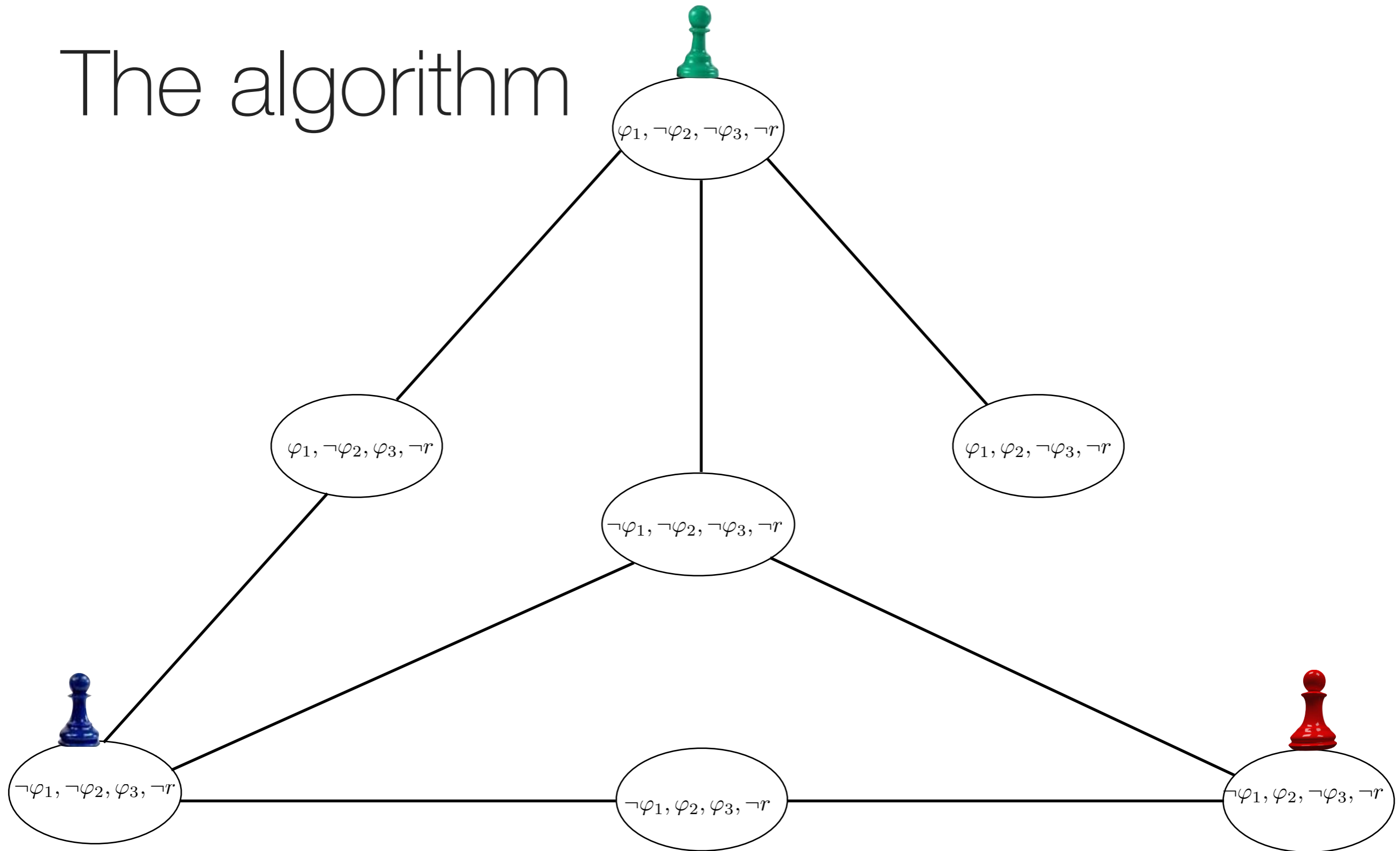

The algorithm

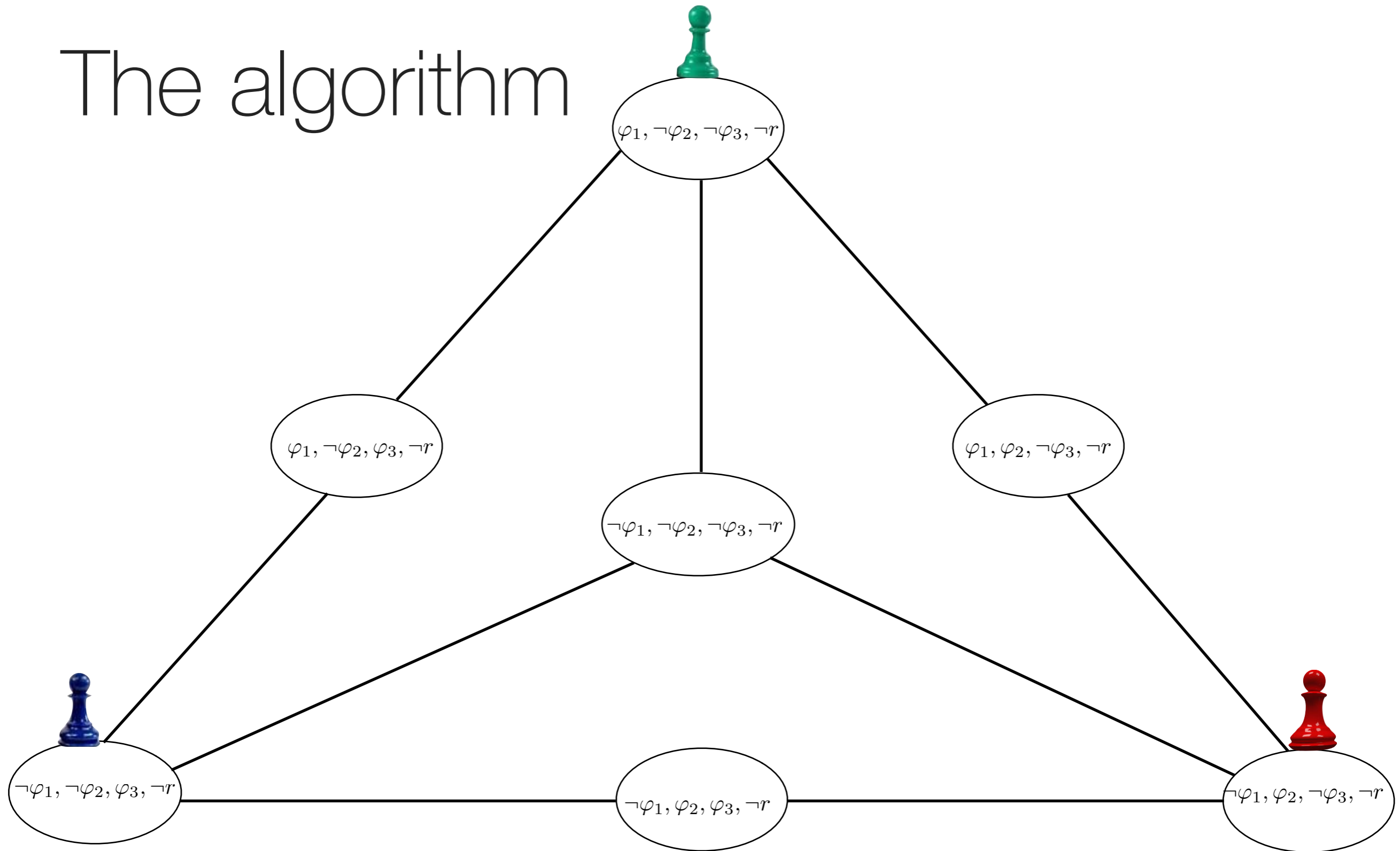

The algorithm

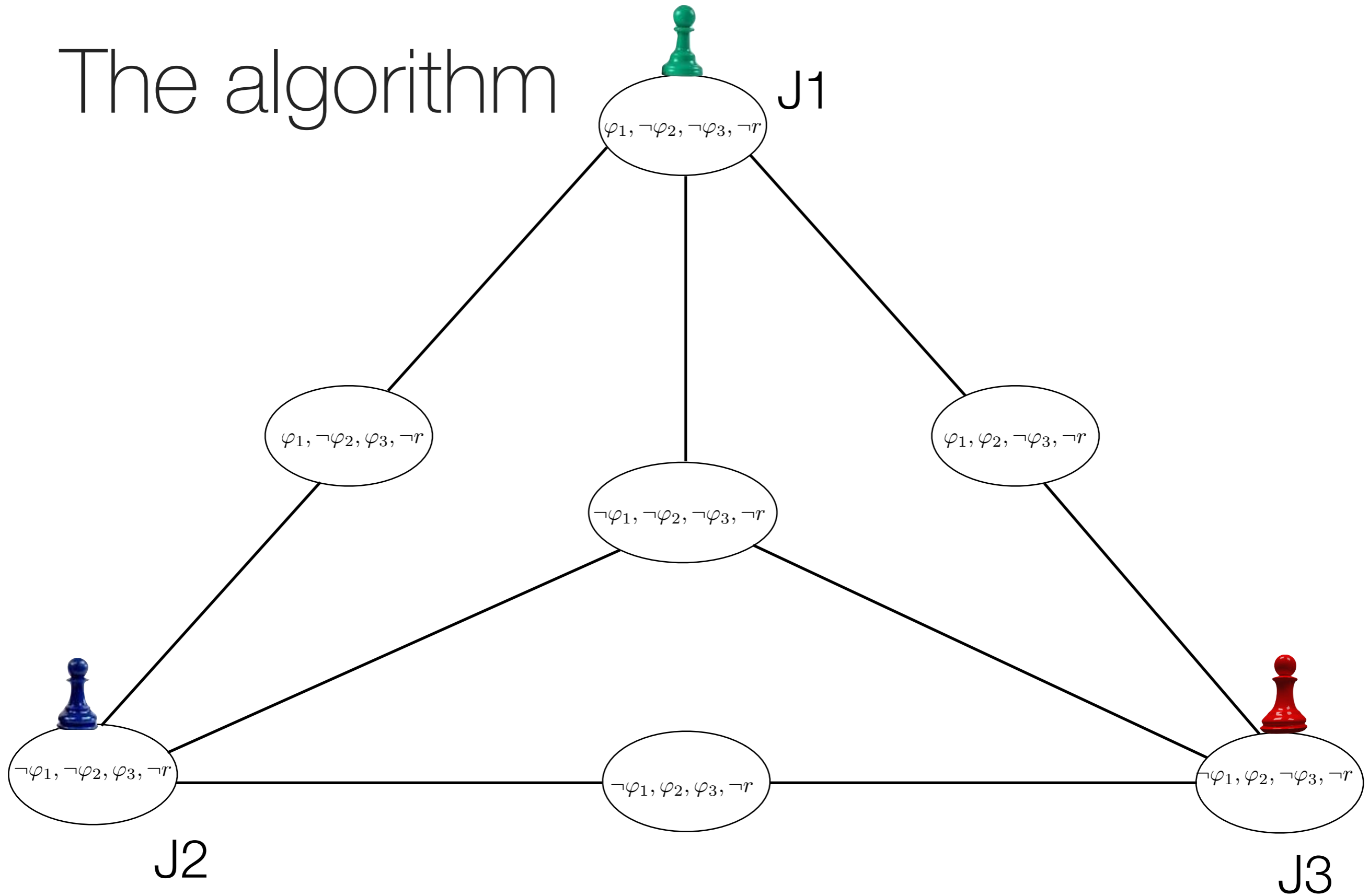

The algorithm

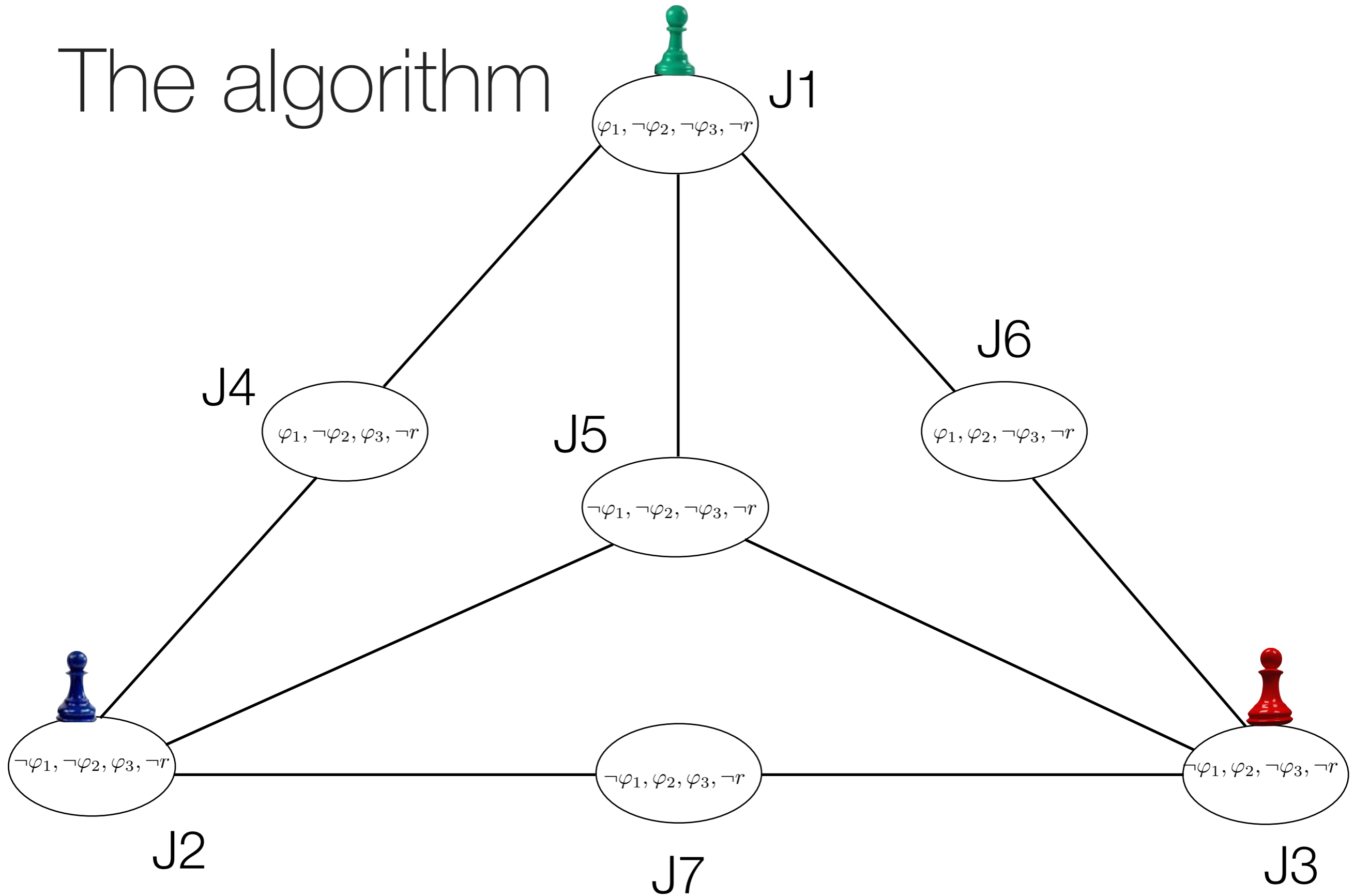

The algorithm

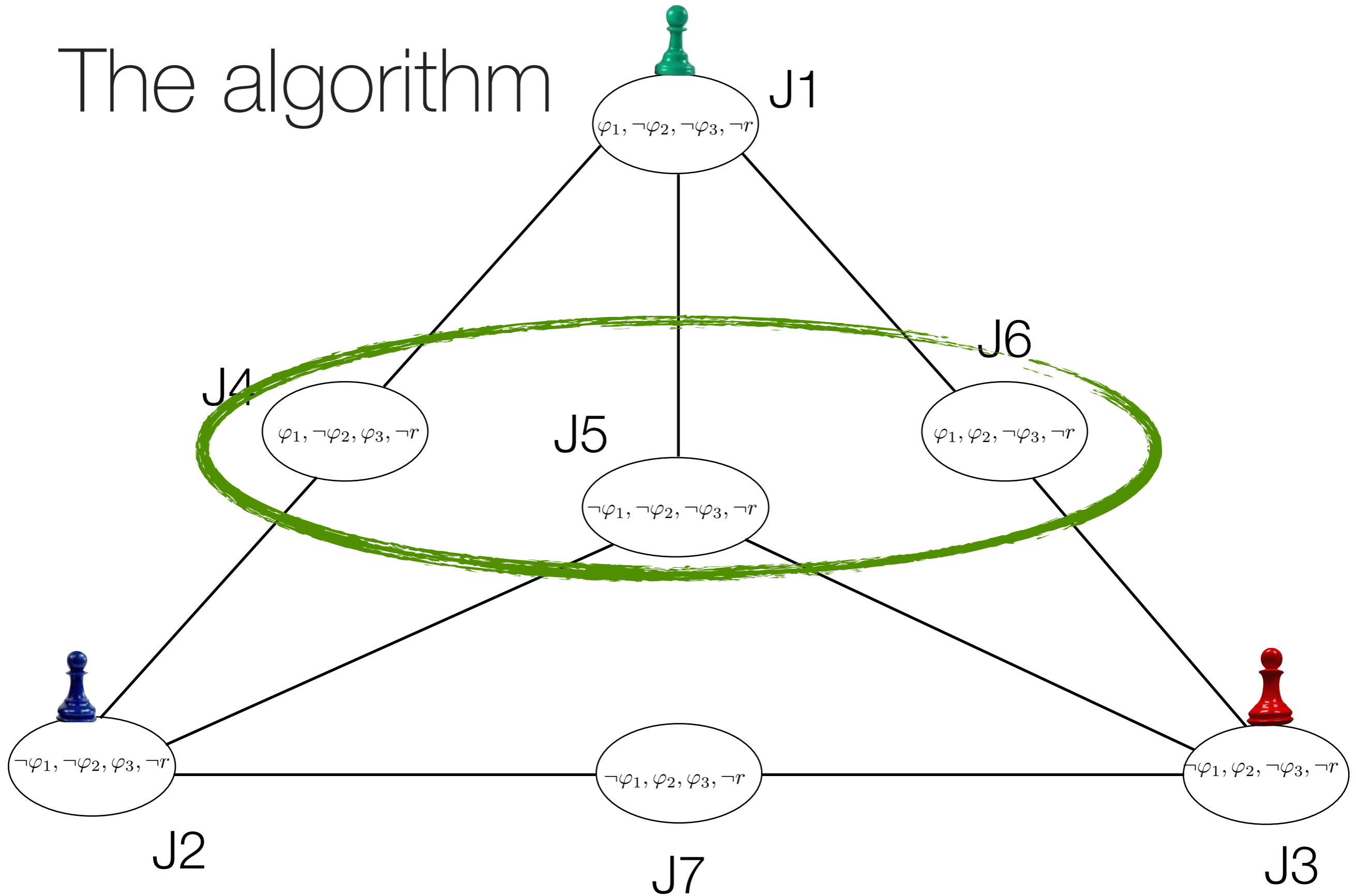

The algorithm

$$d_H(J1, J2) + d_H(J1, J3) = 4$$

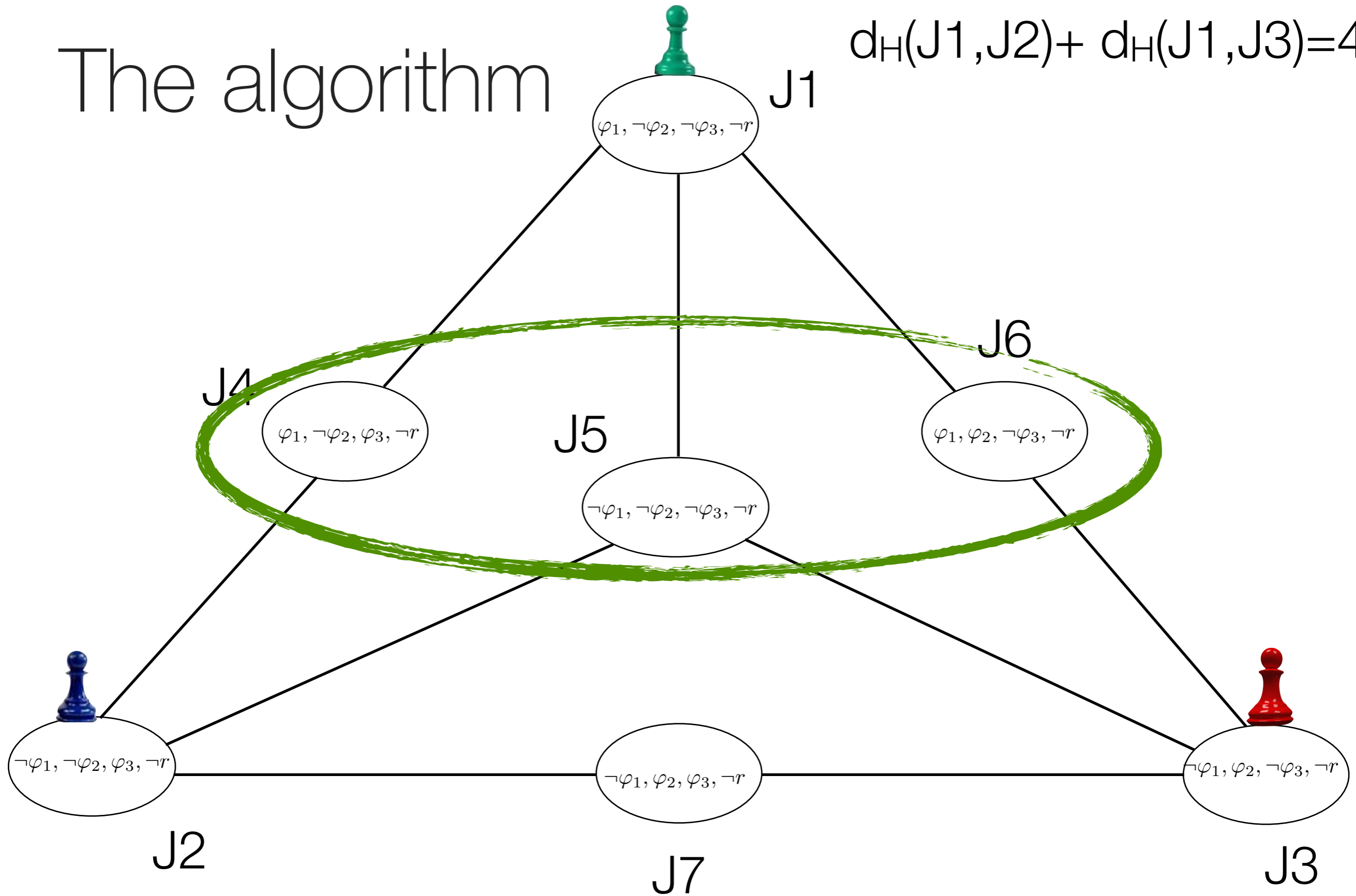

The algorithm

$$d_H(J1, J2) + d_H(J1, J3) = 4$$
$$d_H(J4, J2) + d_H(J4, J3) = 4$$

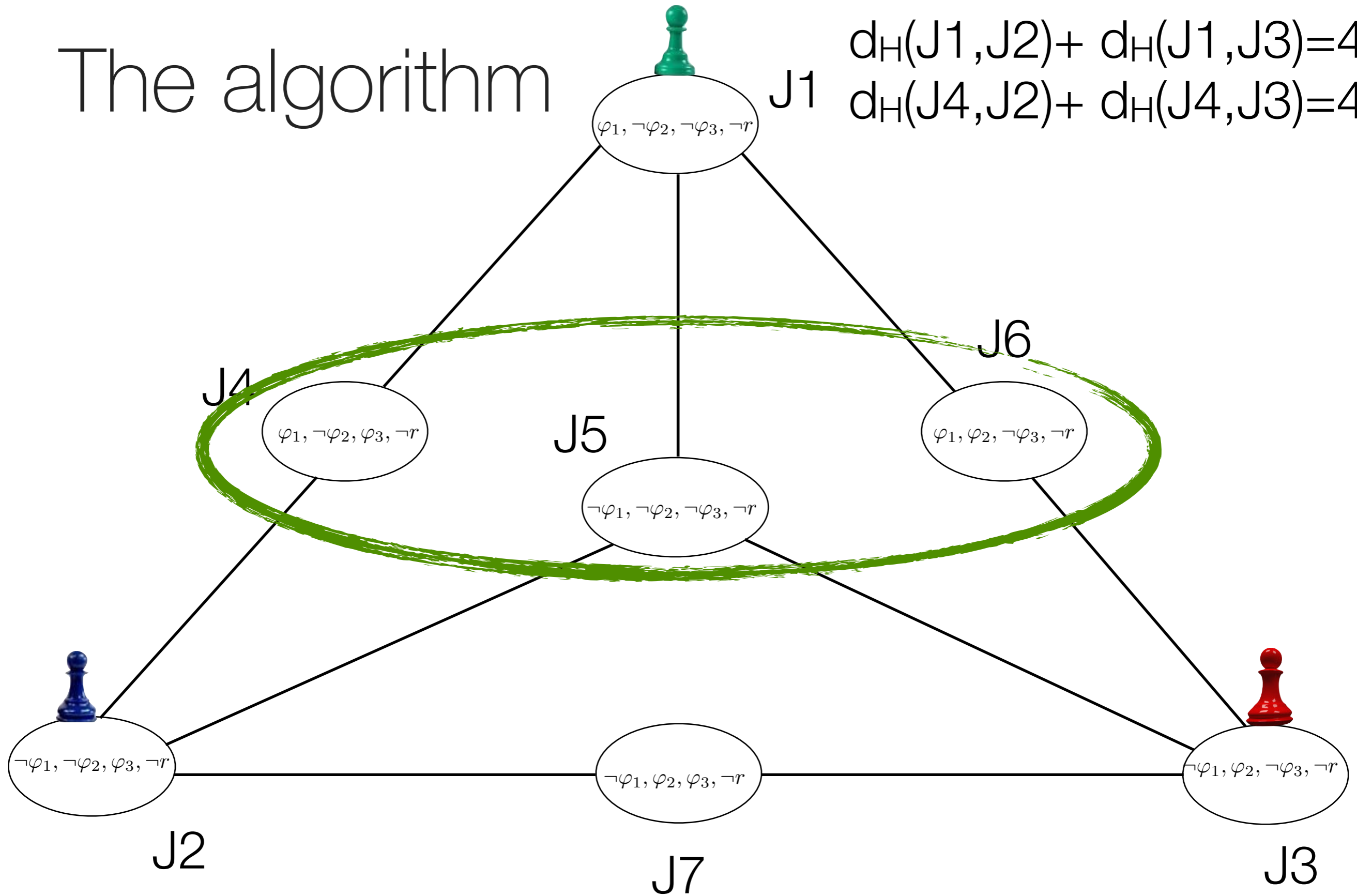

The algorithm

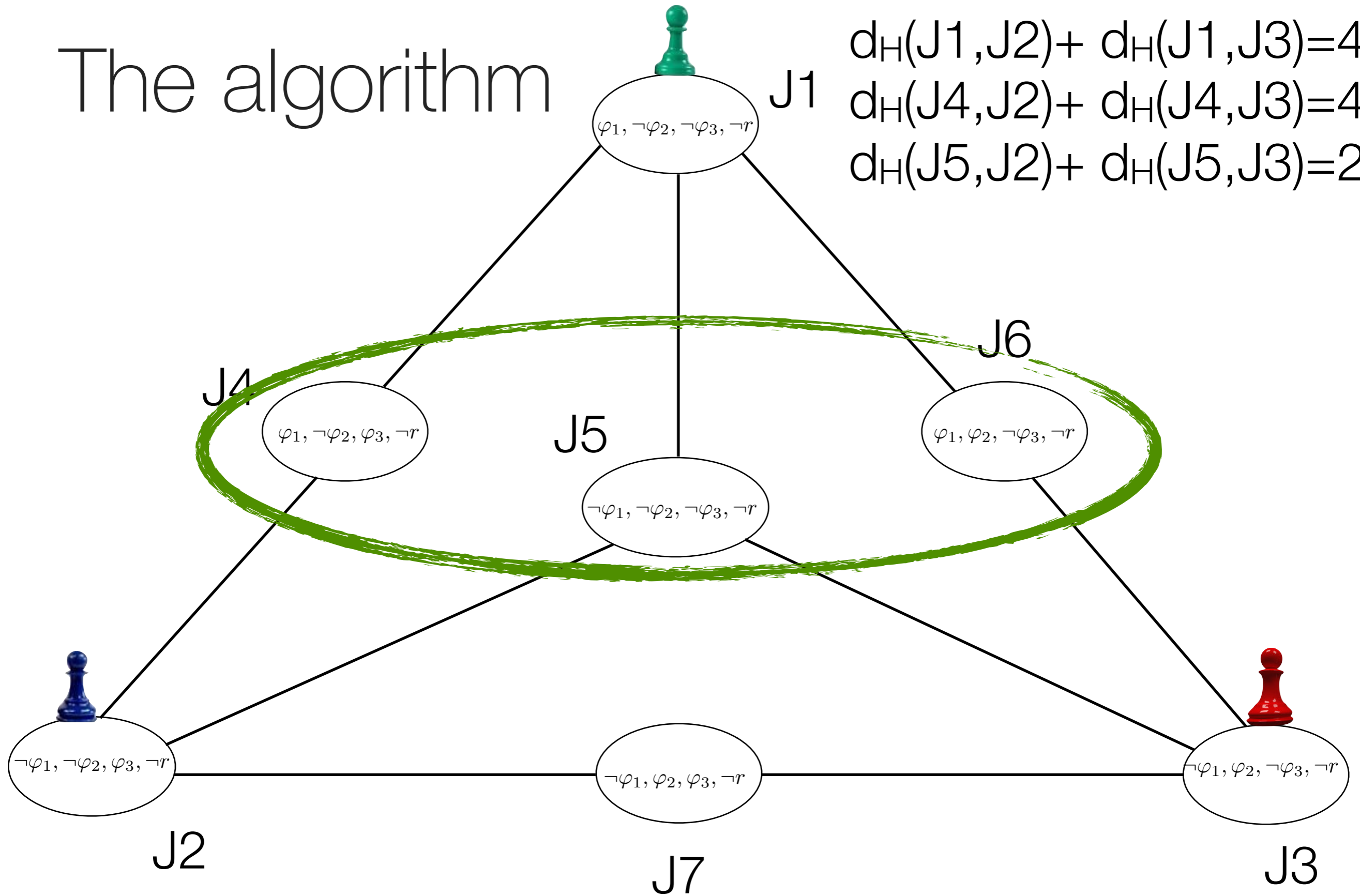

The algorithm

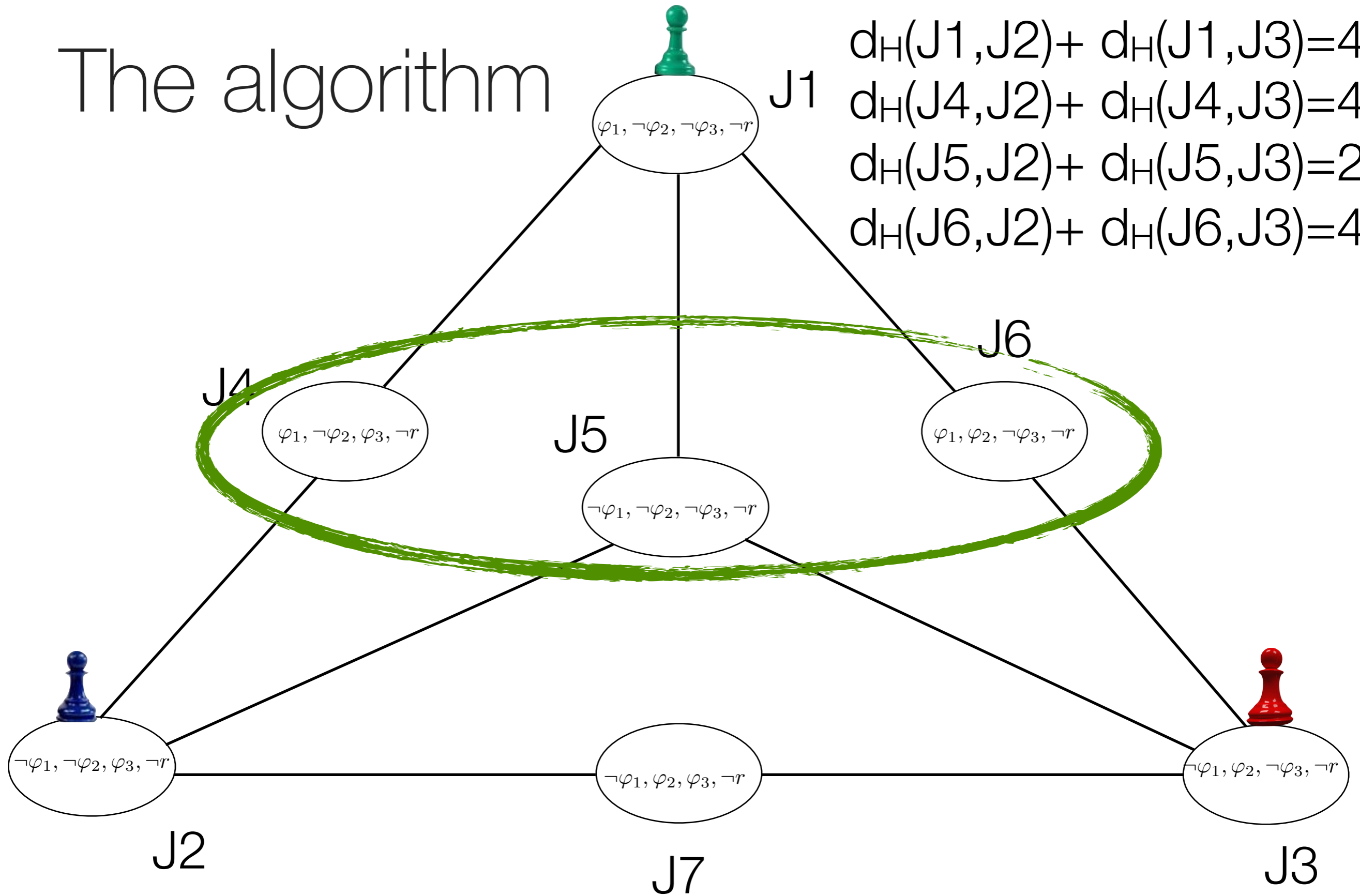

$$\begin{aligned}d_H(J1, J2) + d_H(J1, J3) &= 4 \\d_H(J4, J2) + d_H(J4, J3) &= 4 \\d_H(J5, J2) + d_H(J5, J3) &= 2 \\d_H(J6, J2) + d_H(J6, J3) &= 4\end{aligned}$$

The algorithm

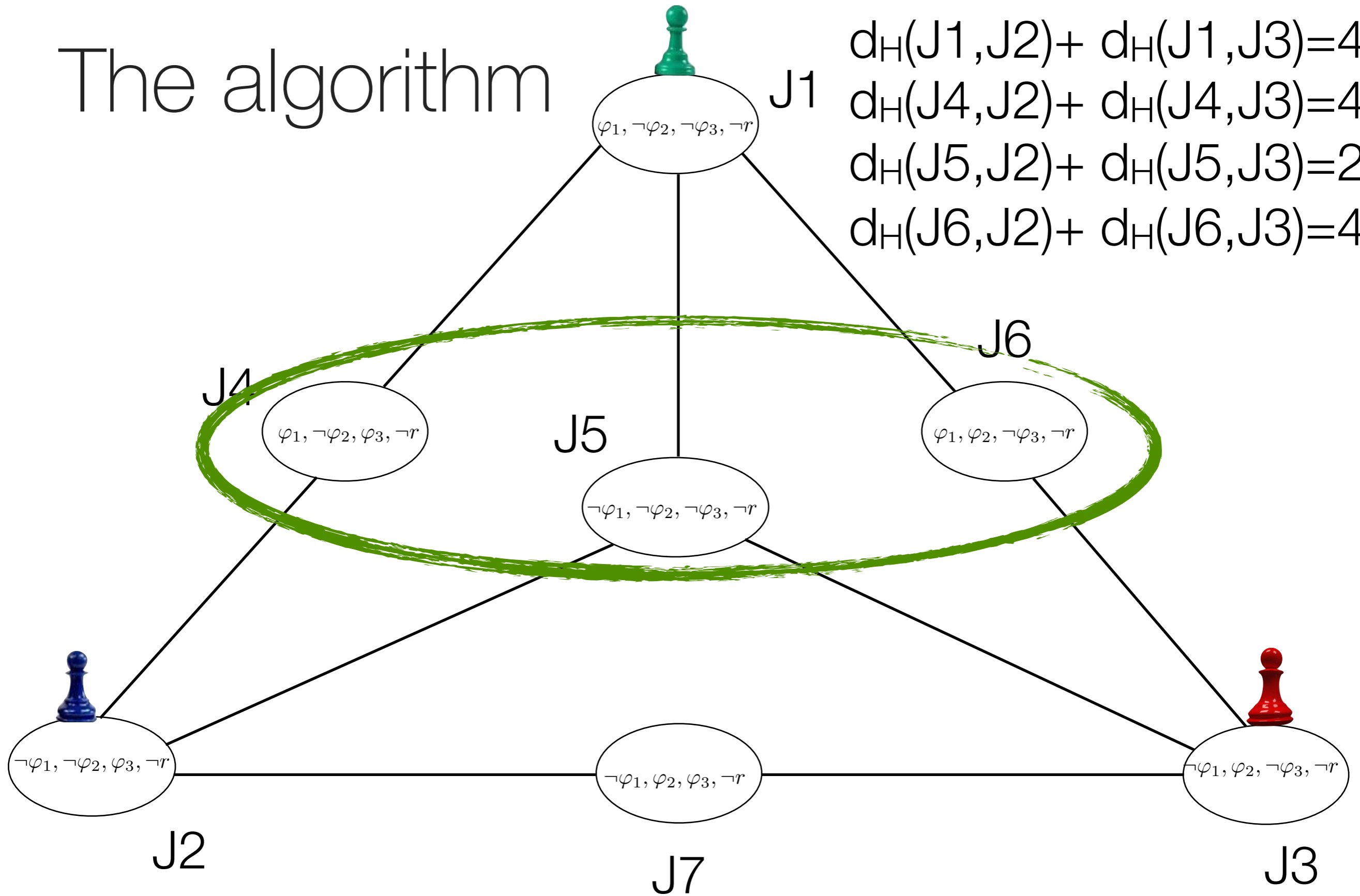

$$\begin{aligned}d_H(J1, J2) + d_H(J1, J3) &= 4 \\d_H(J4, J2) + d_H(J4, J3) &= 4 \\d_H(J5, J2) + d_H(J5, J3) &= 2 \\d_H(J6, J2) + d_H(J6, J3) &= 4\end{aligned}$$

The algorithm

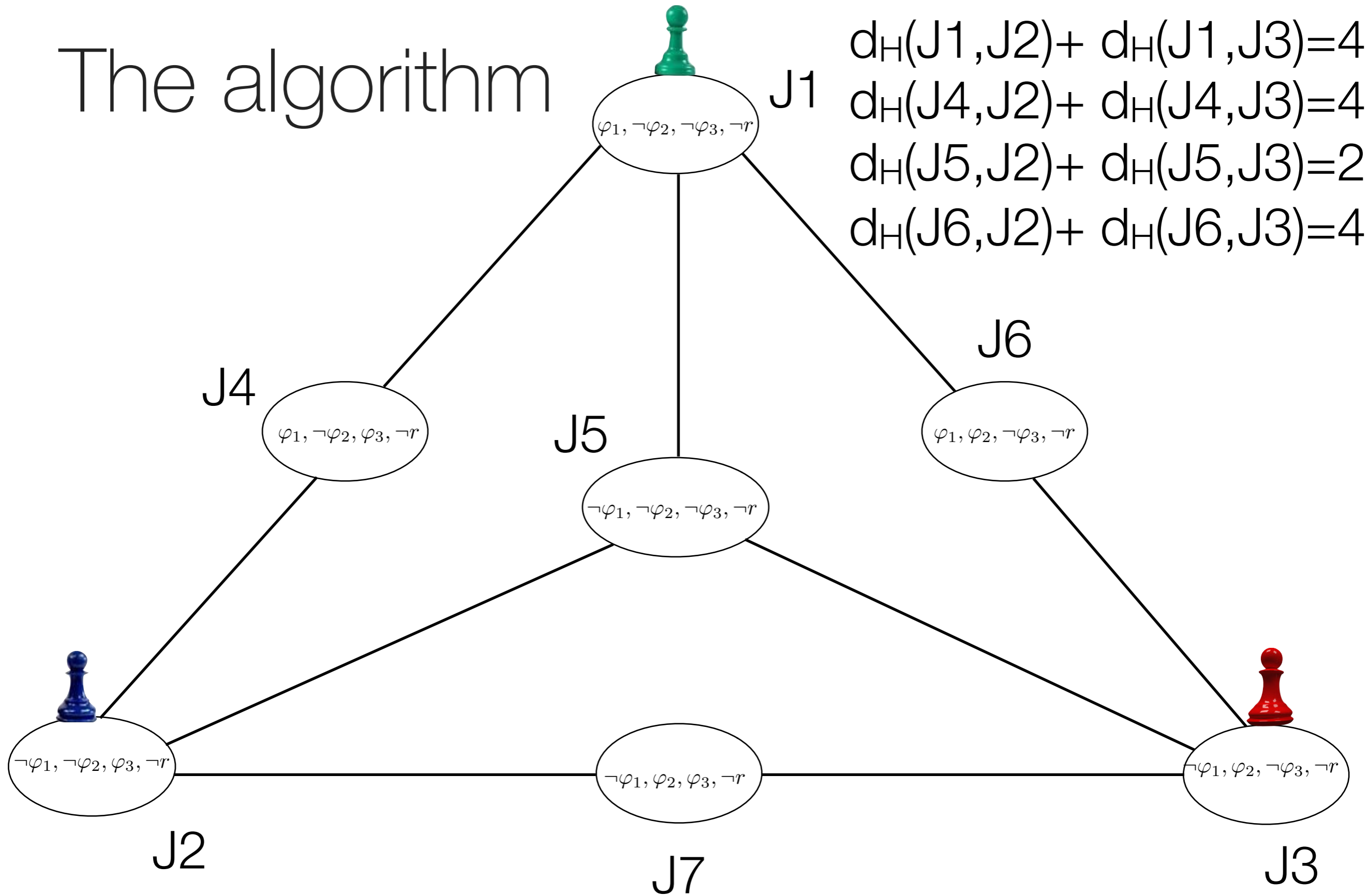

The algorithm

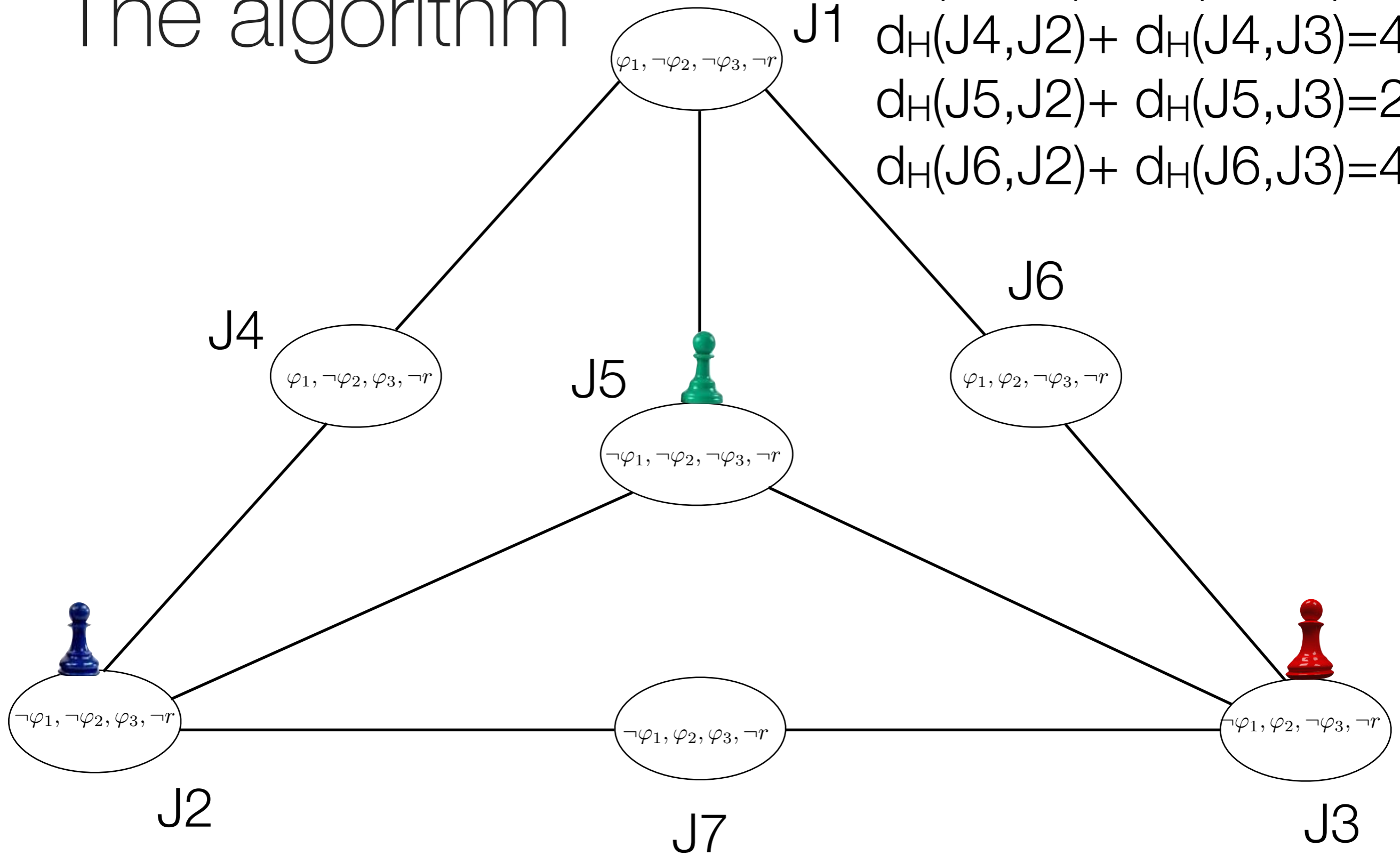

$$\begin{aligned}d_H(J1, J2) + d_H(J1, J3) &= 4 \\d_H(J4, J2) + d_H(J4, J3) &= 4 \\d_H(J5, J2) + d_H(J5, J3) &= 2 \\d_H(J6, J2) + d_H(J6, J3) &= 4\end{aligned}$$

The algorithm

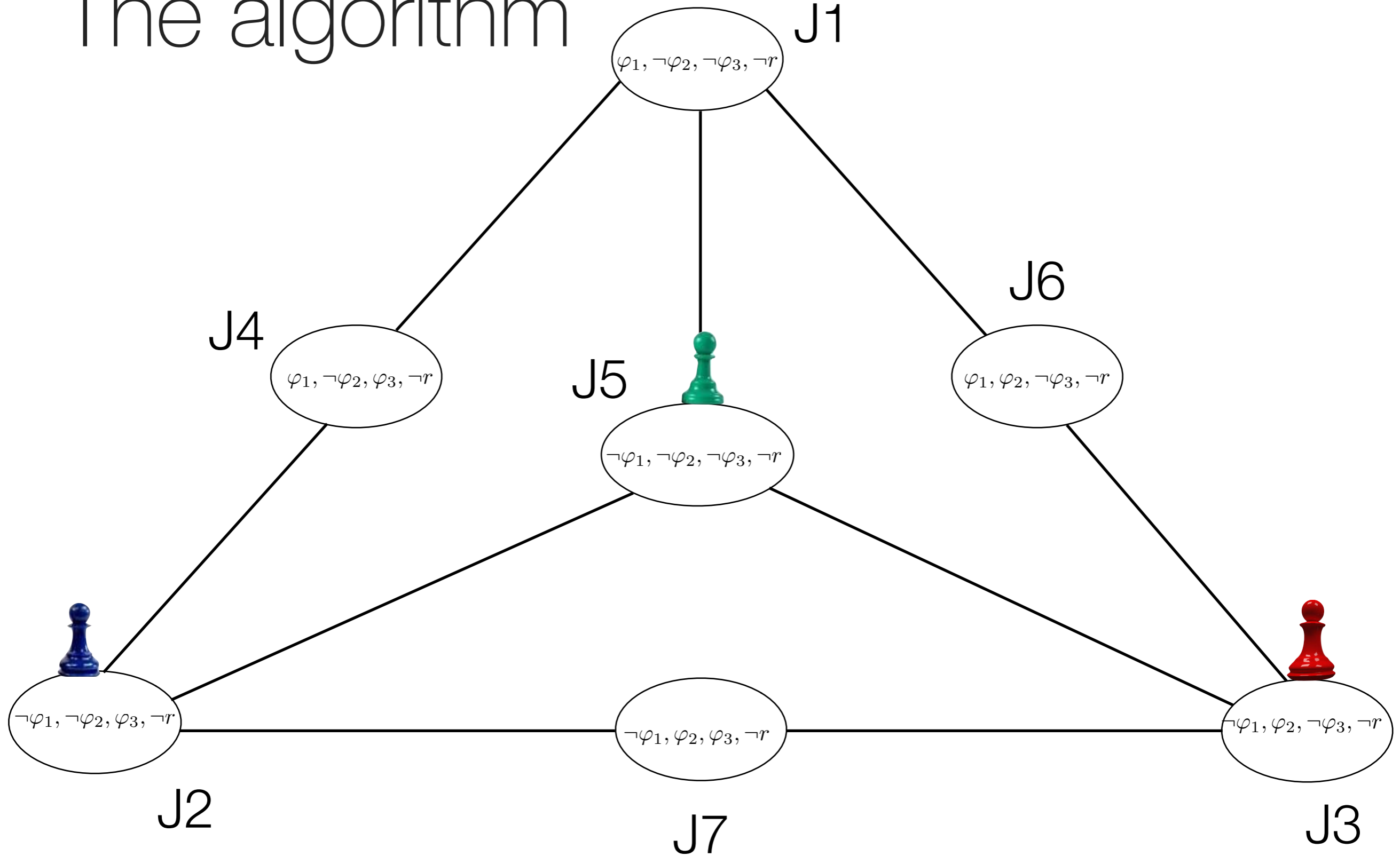

The algorithm

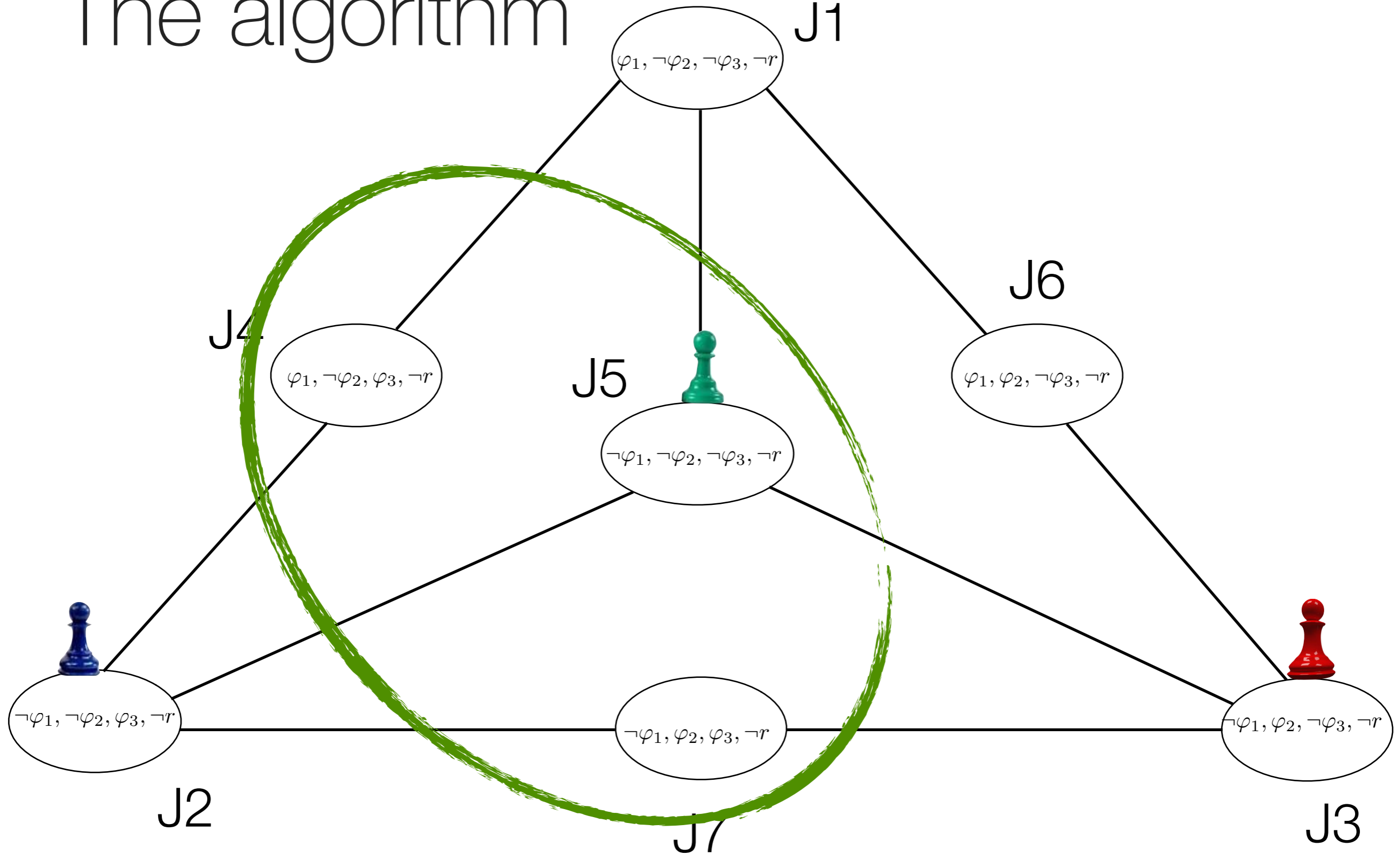

The algorithm

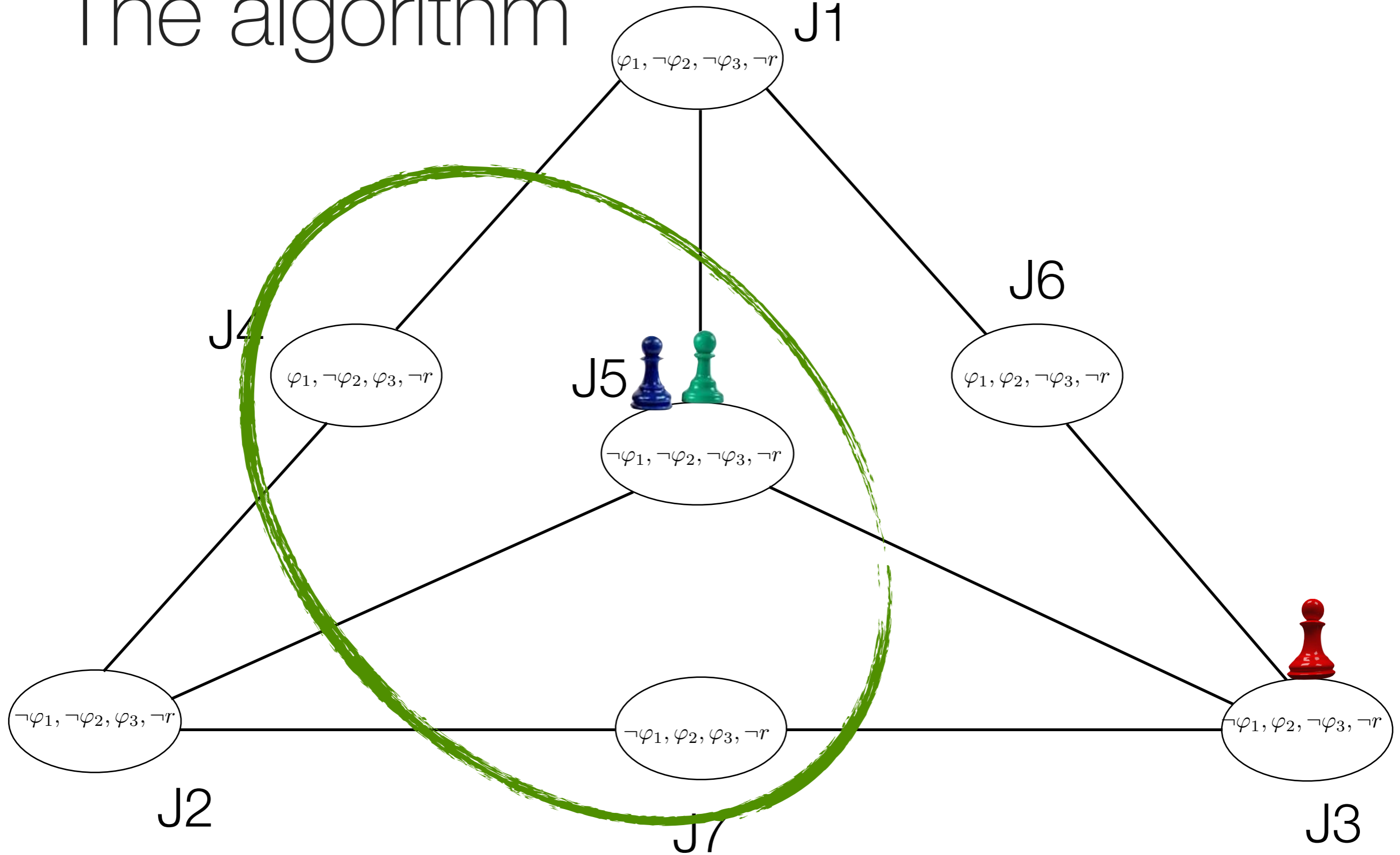

The algorithm

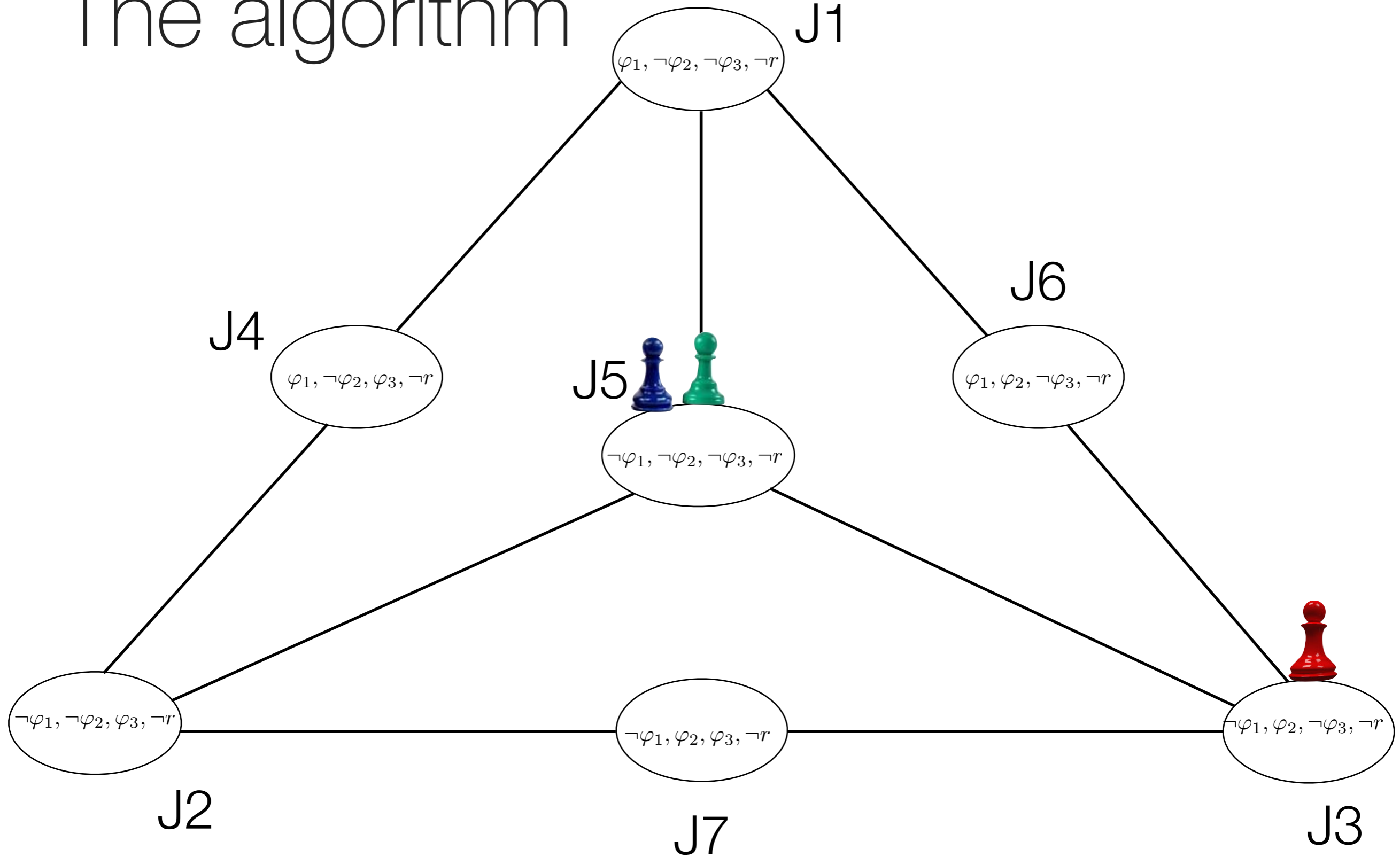

The algorithm

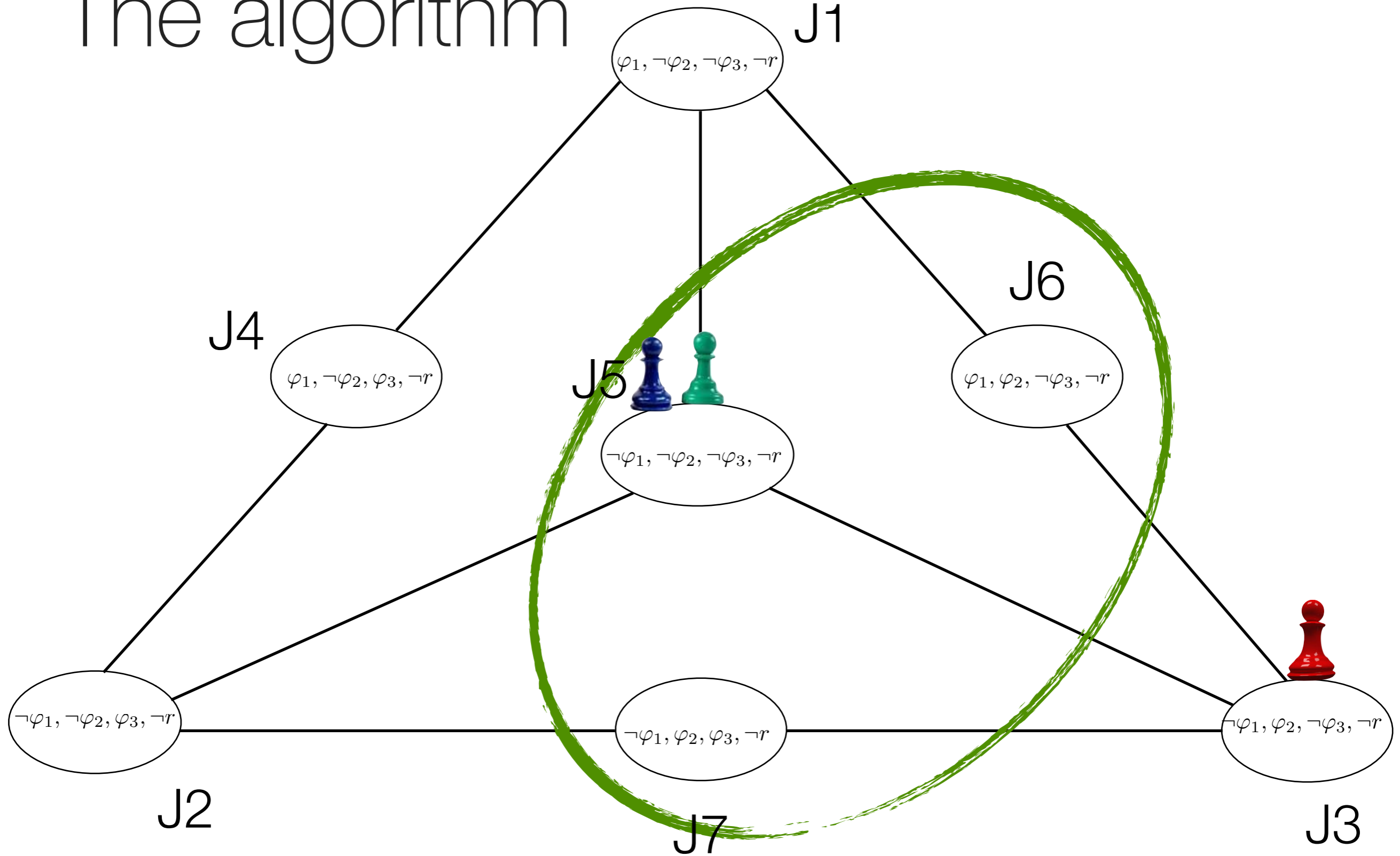

The algorithm

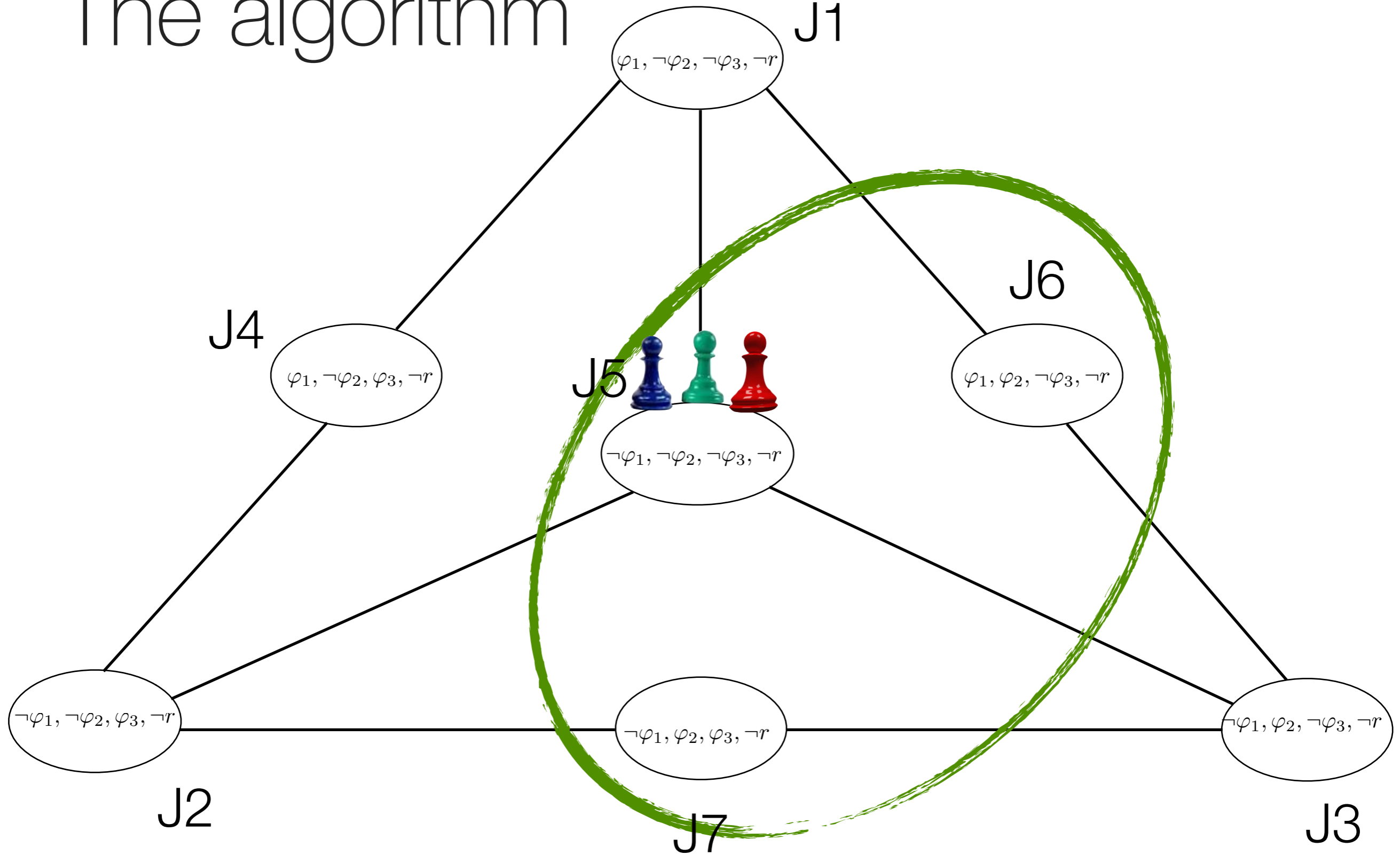

The algorithm

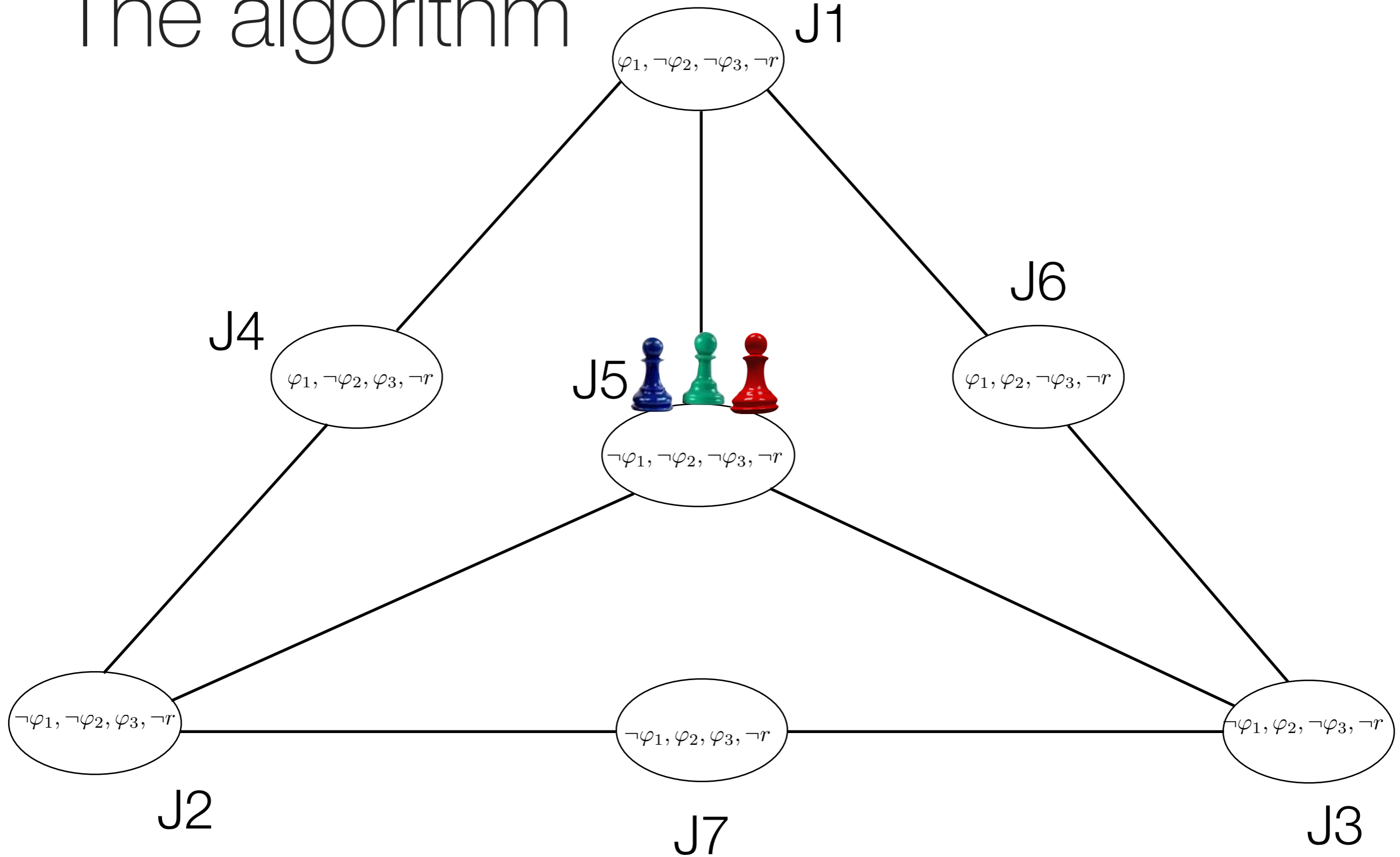

When does the algorithm (probabilistically) terminate?

Necessary conditions:

- Odd number of agents
- Connected profile

Connected & not connected profile

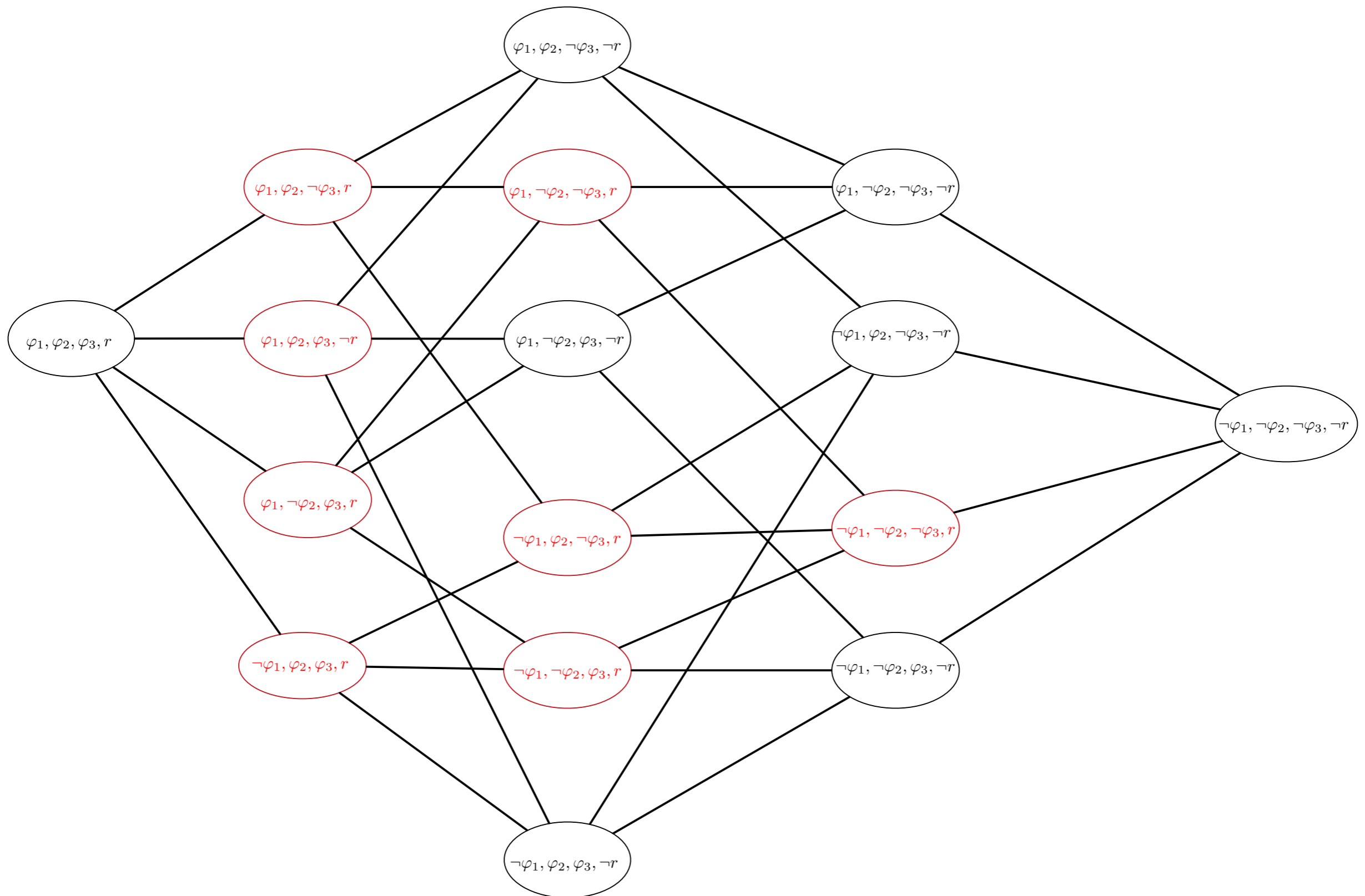

Connected & not connected profile

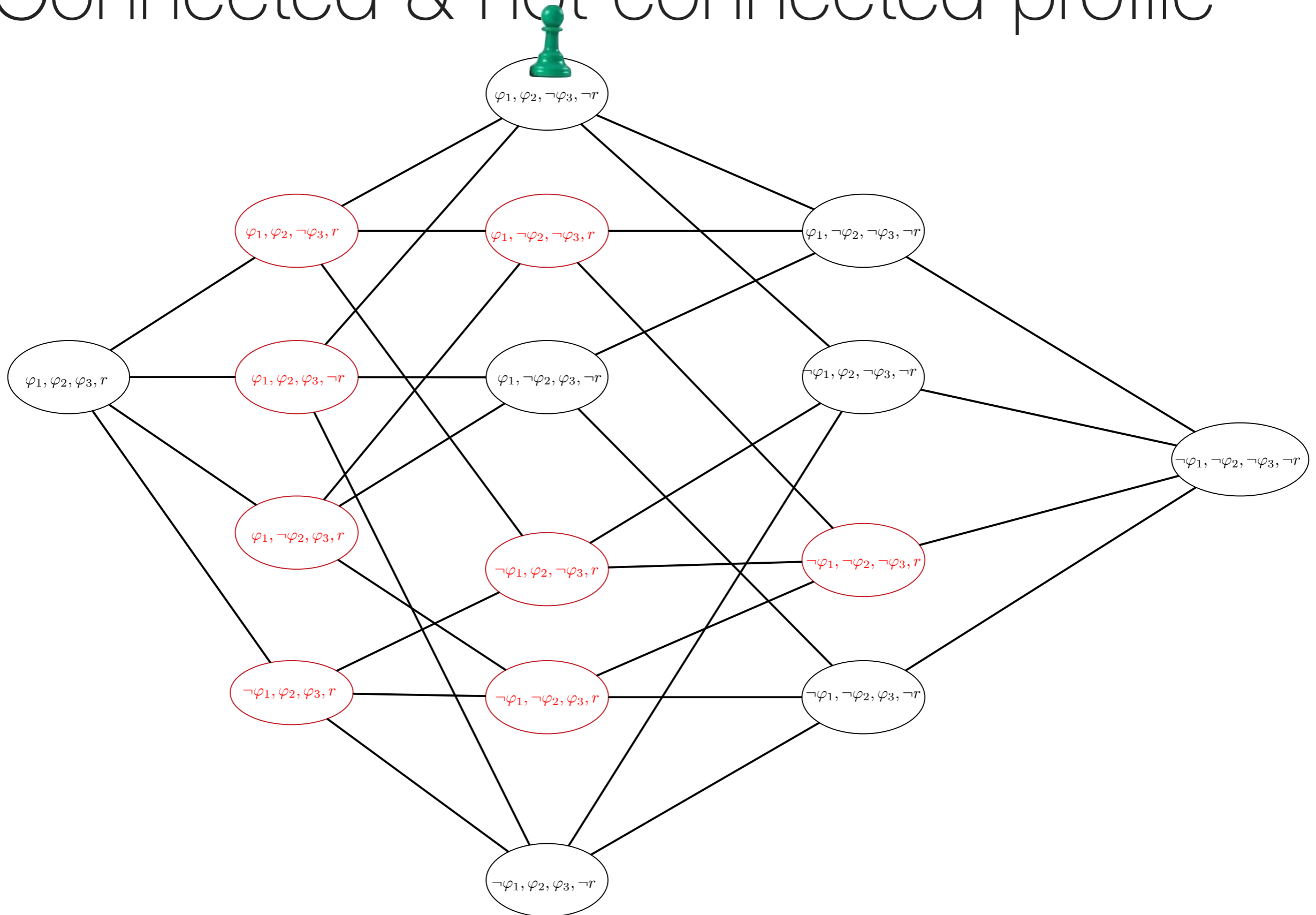

Connected & not connected profile

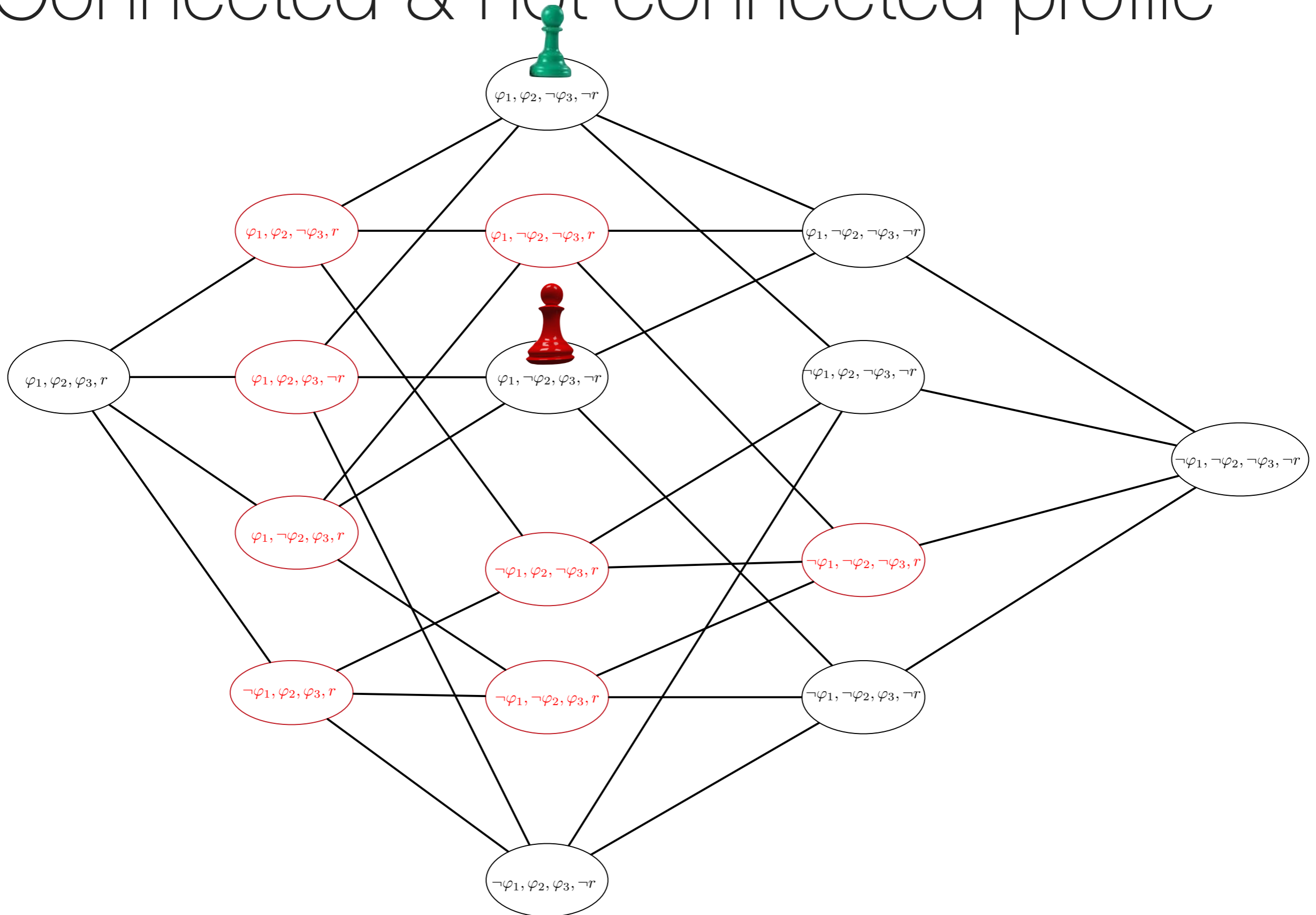

Connected & not connected profile

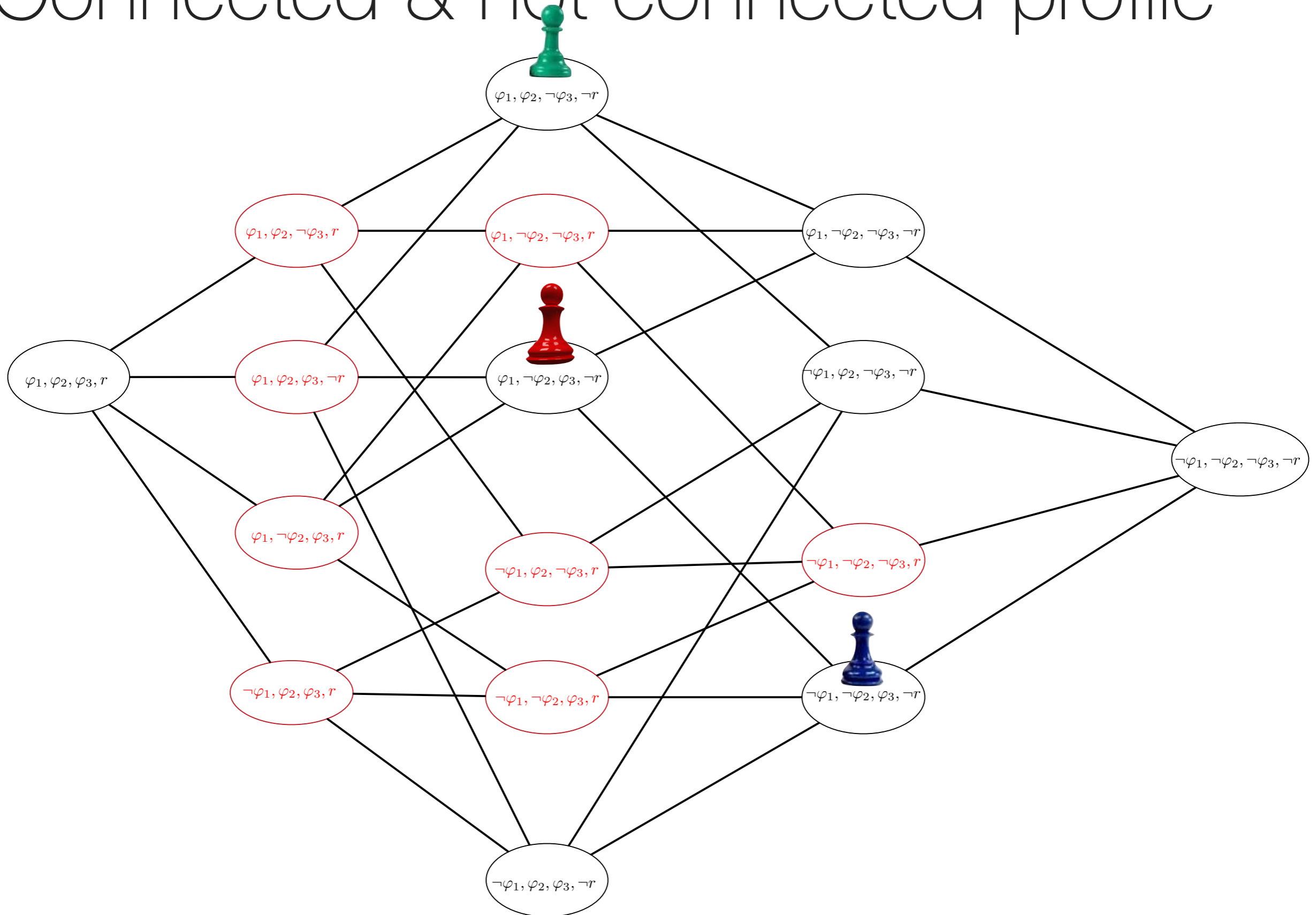

Connected & not connected profile

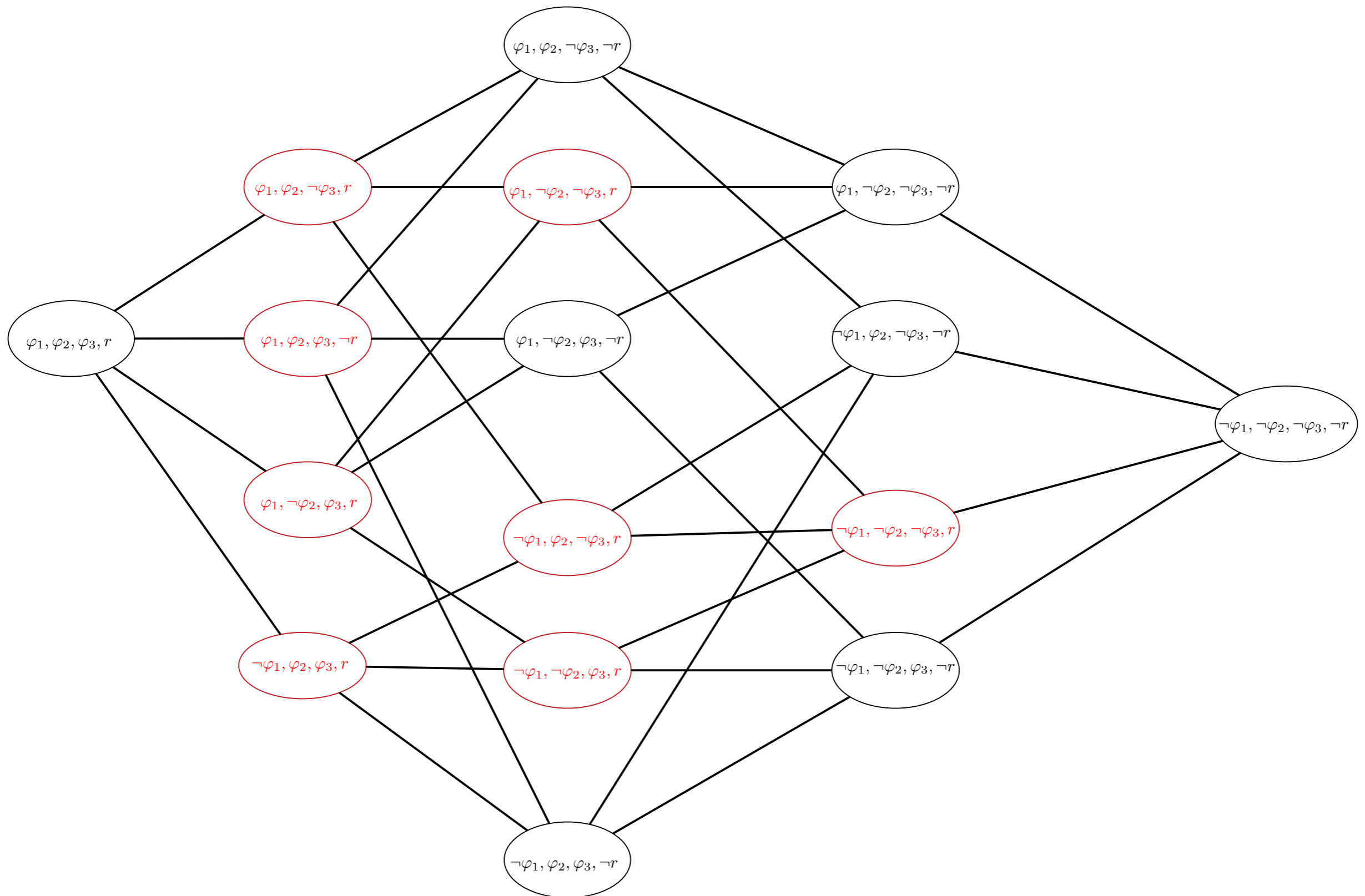

Connected & not connected profile

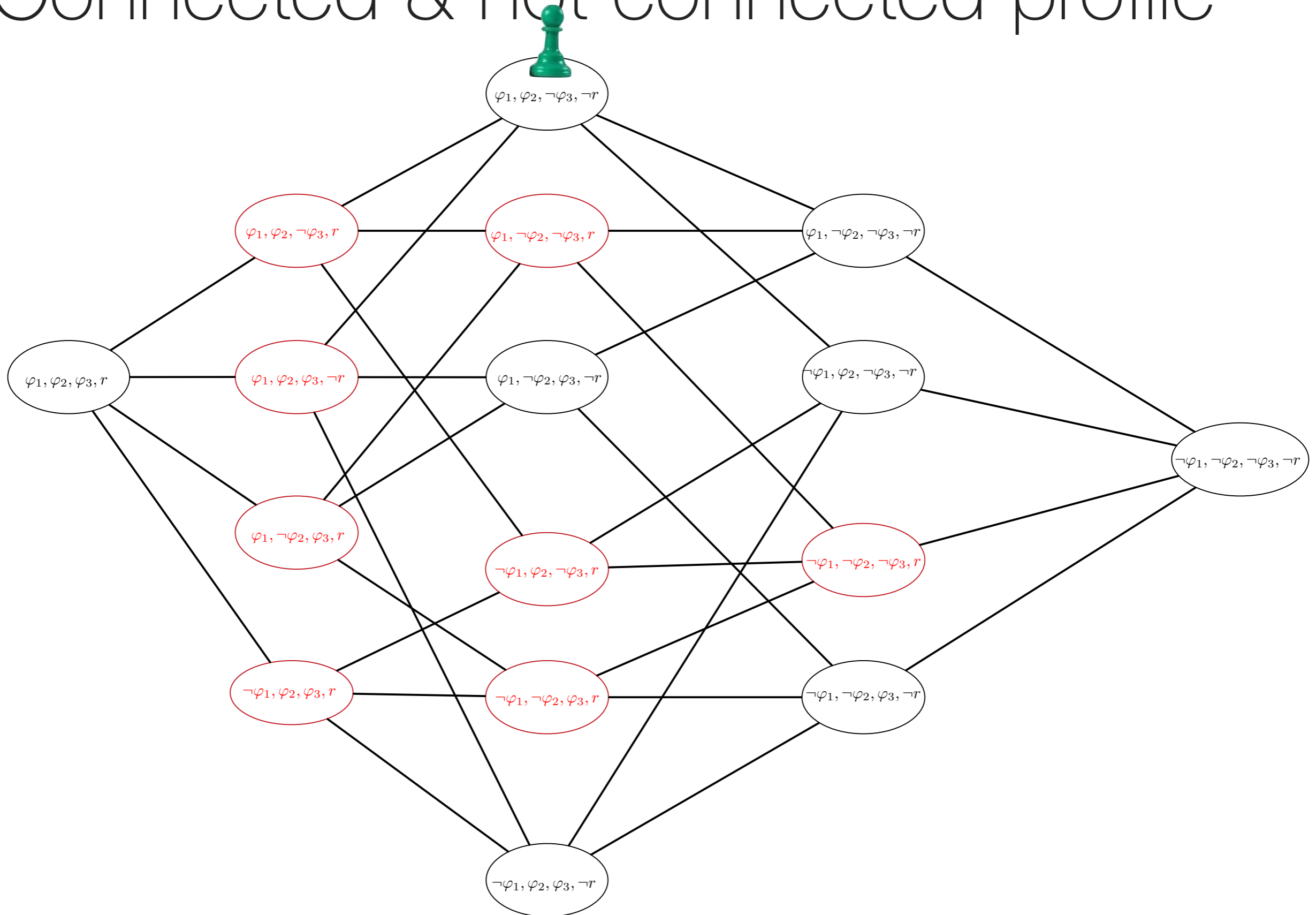

Connected & not connected profile

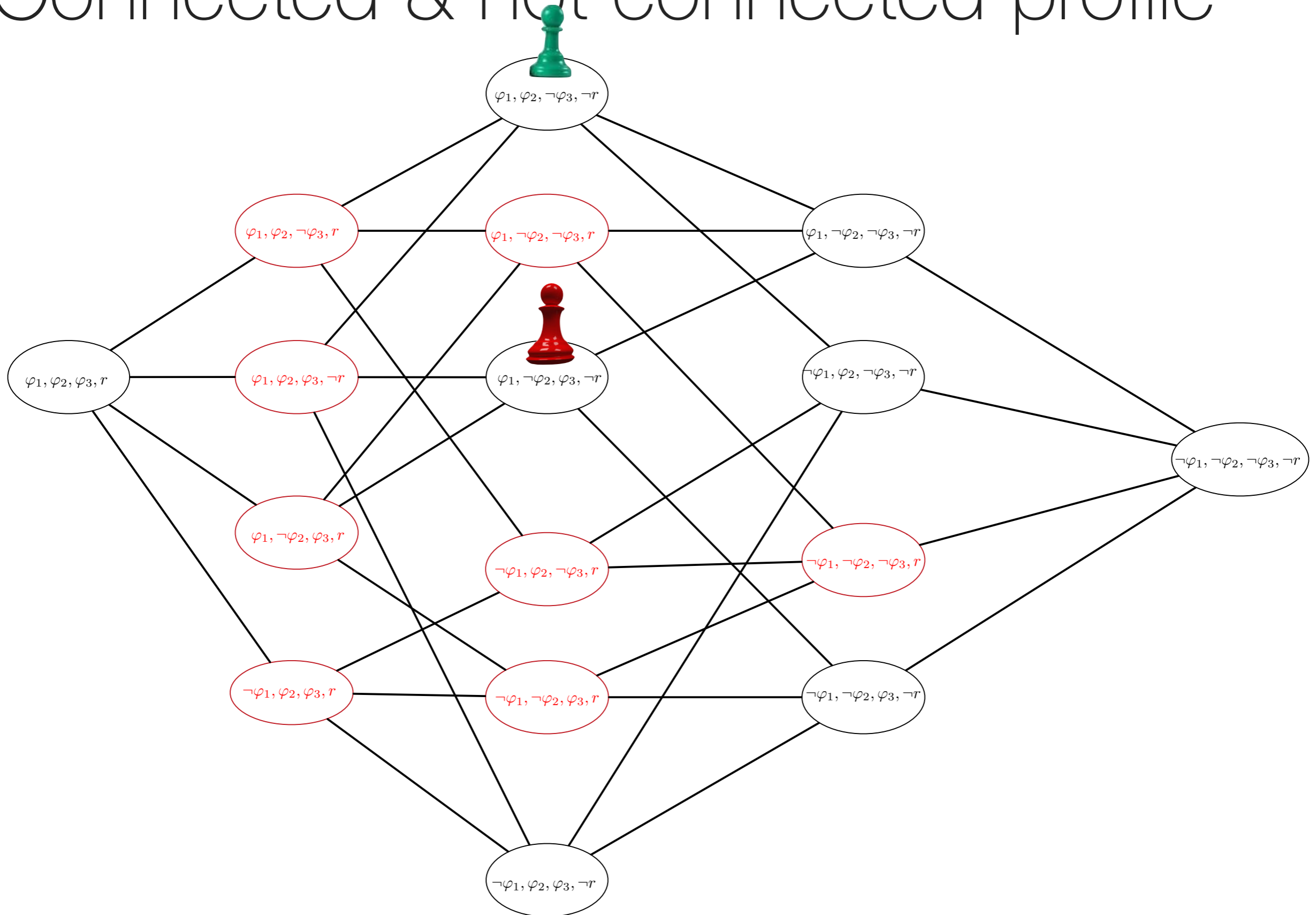

Connected & not connected profile

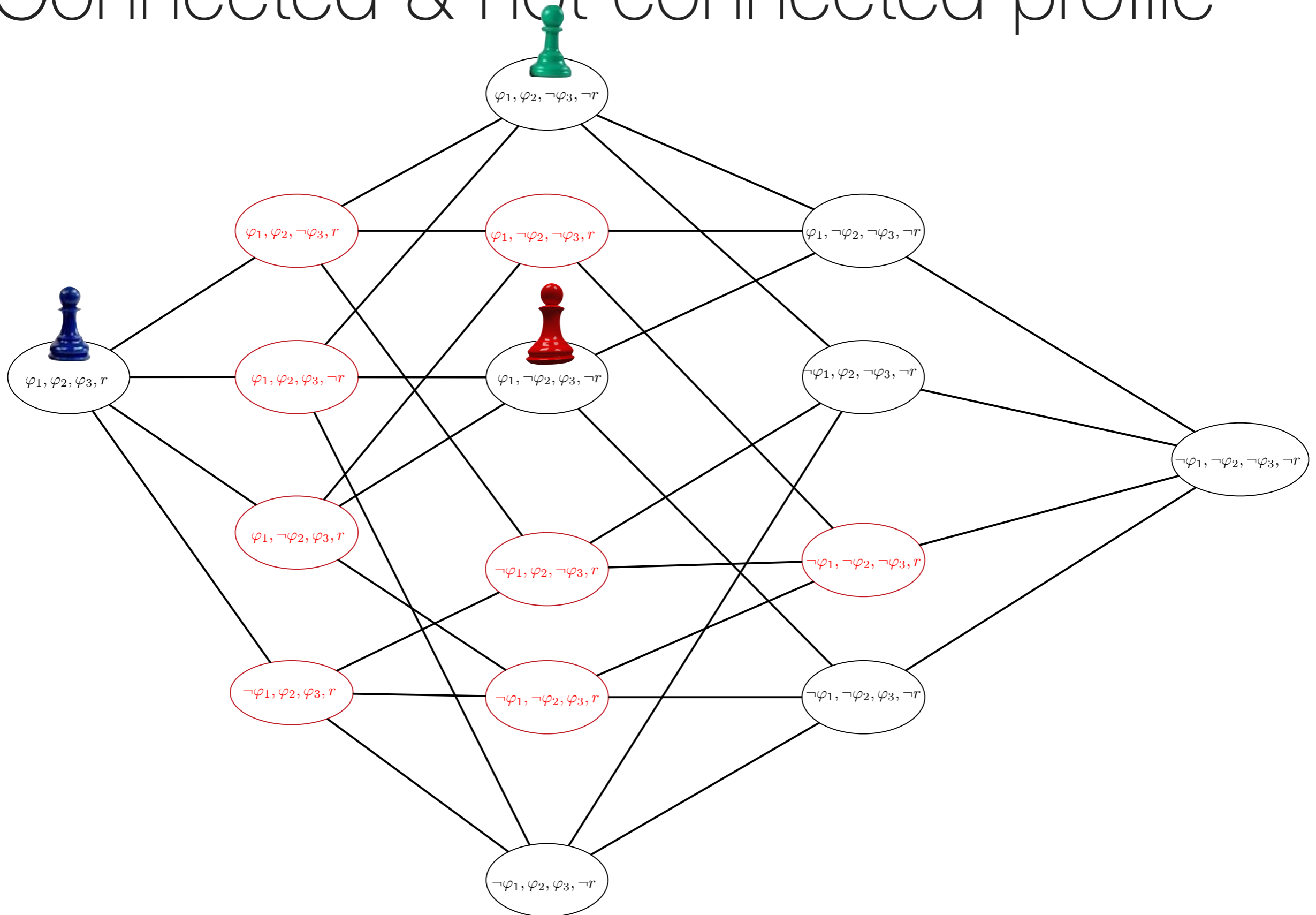

Connected & not connected profile

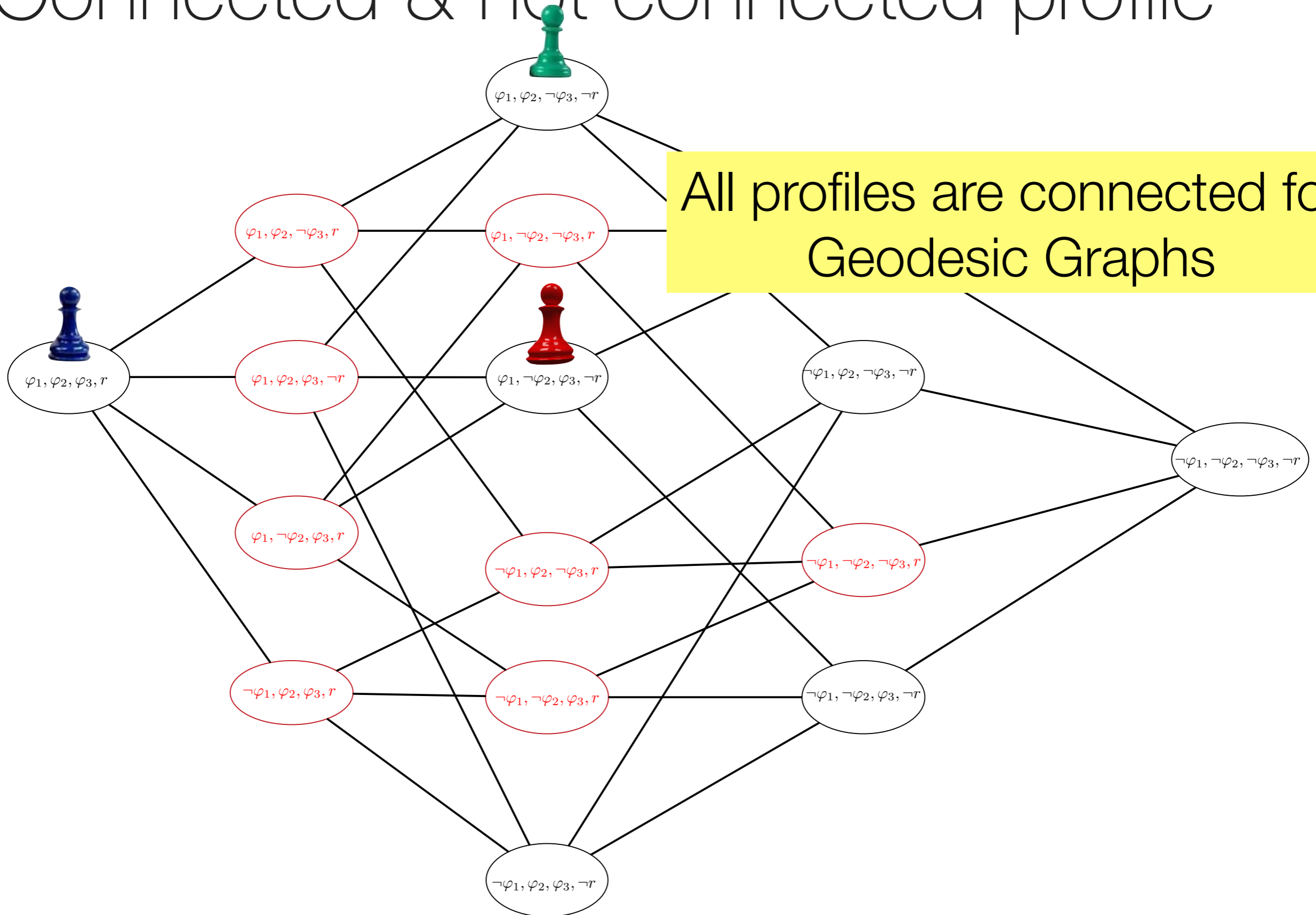

When does the algorithm (probabilistically) terminate?

Sufficient conditions:

- More than 3 agents
- Good shape of profile subgraph

Problem with 3 agents

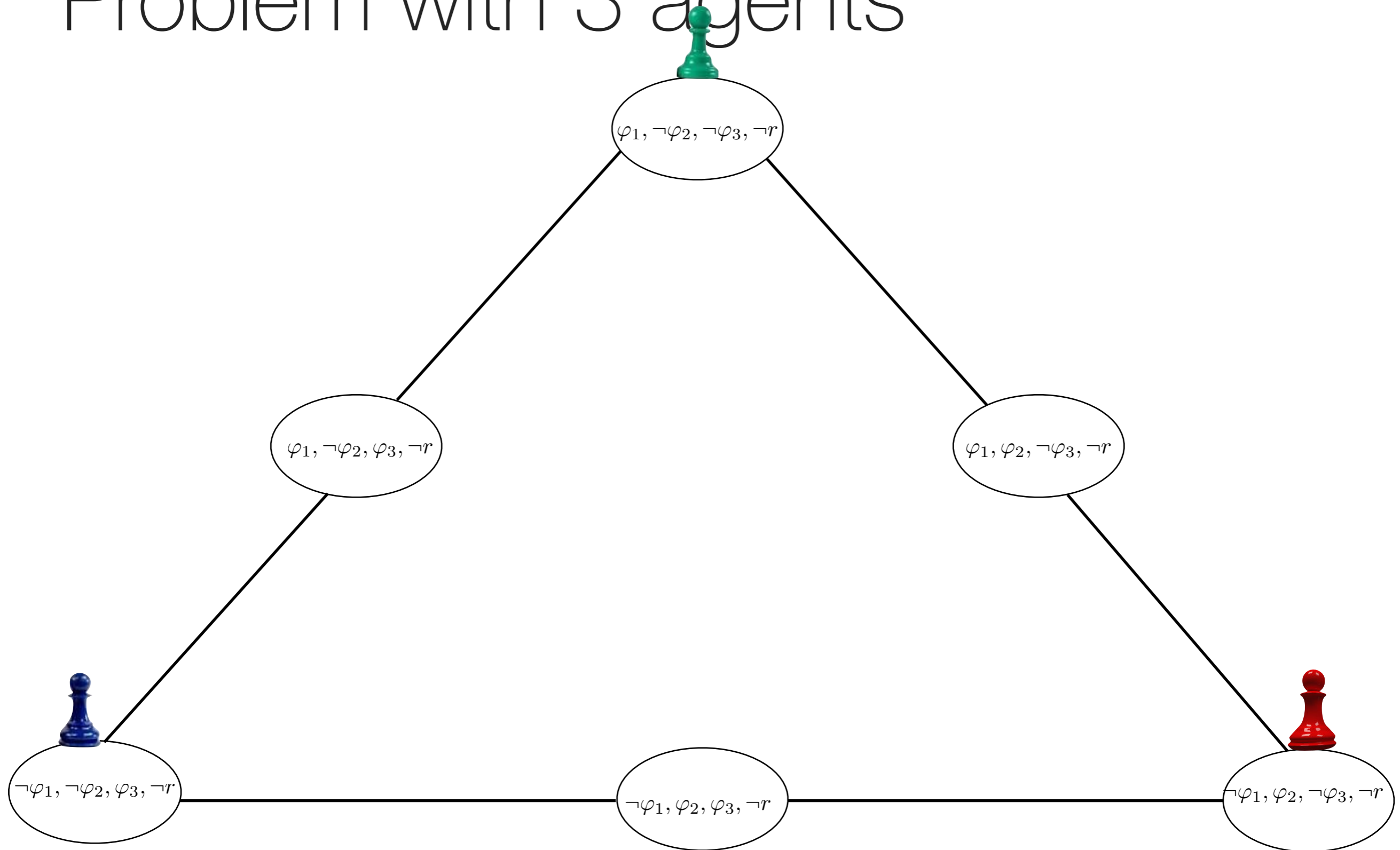

Problem with 3 agents

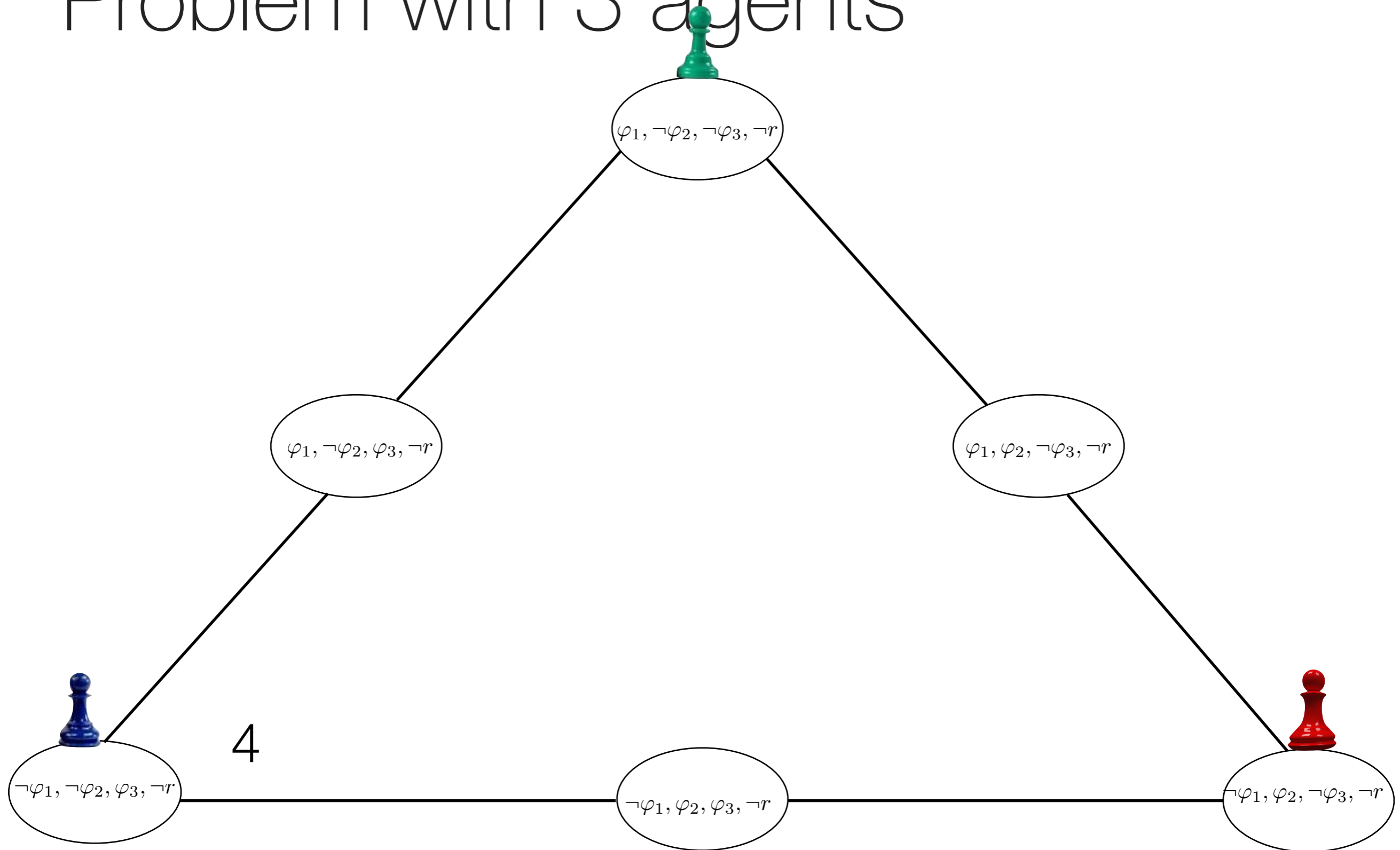

Problem with 3 agents

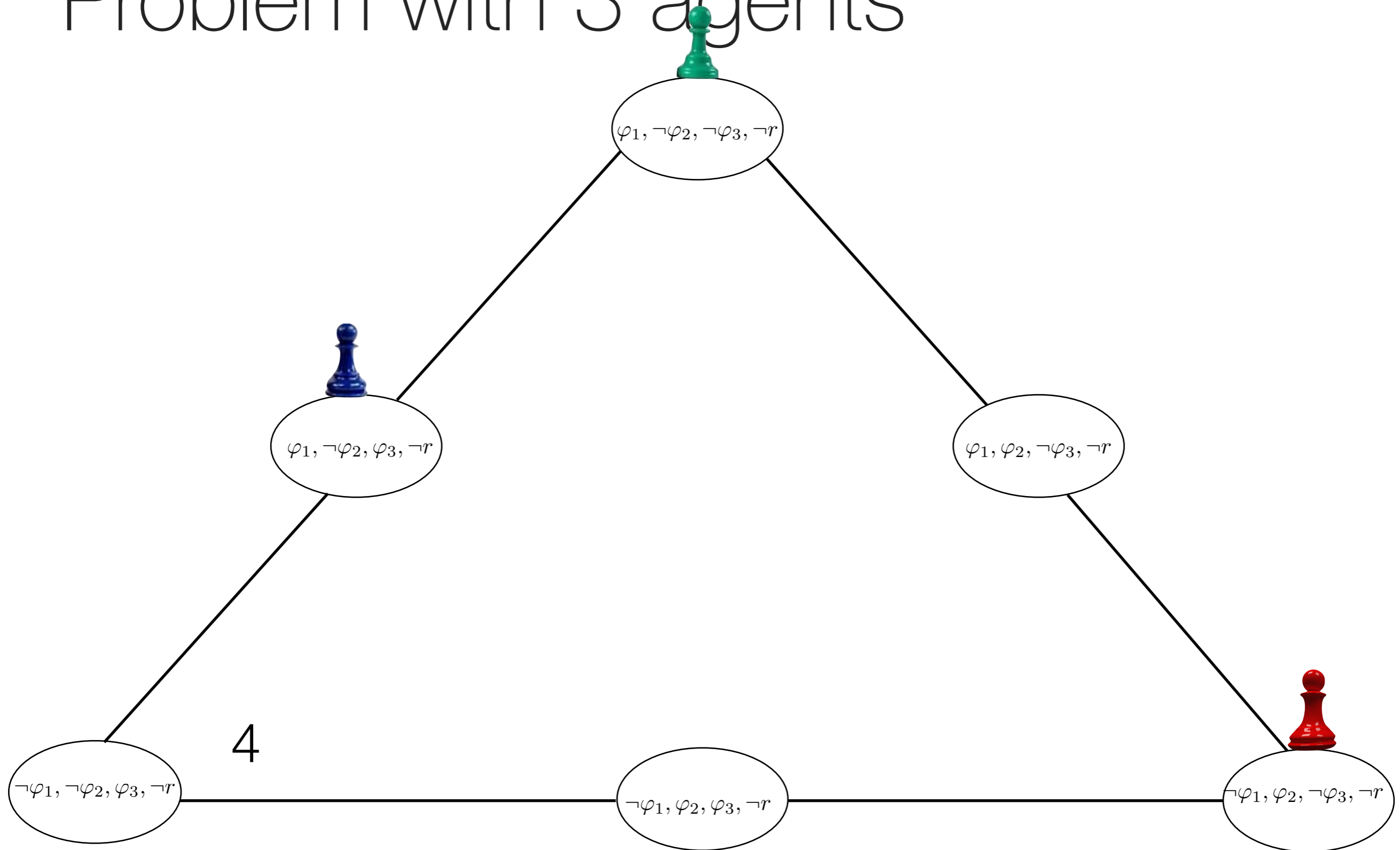

Problem with 3 agents

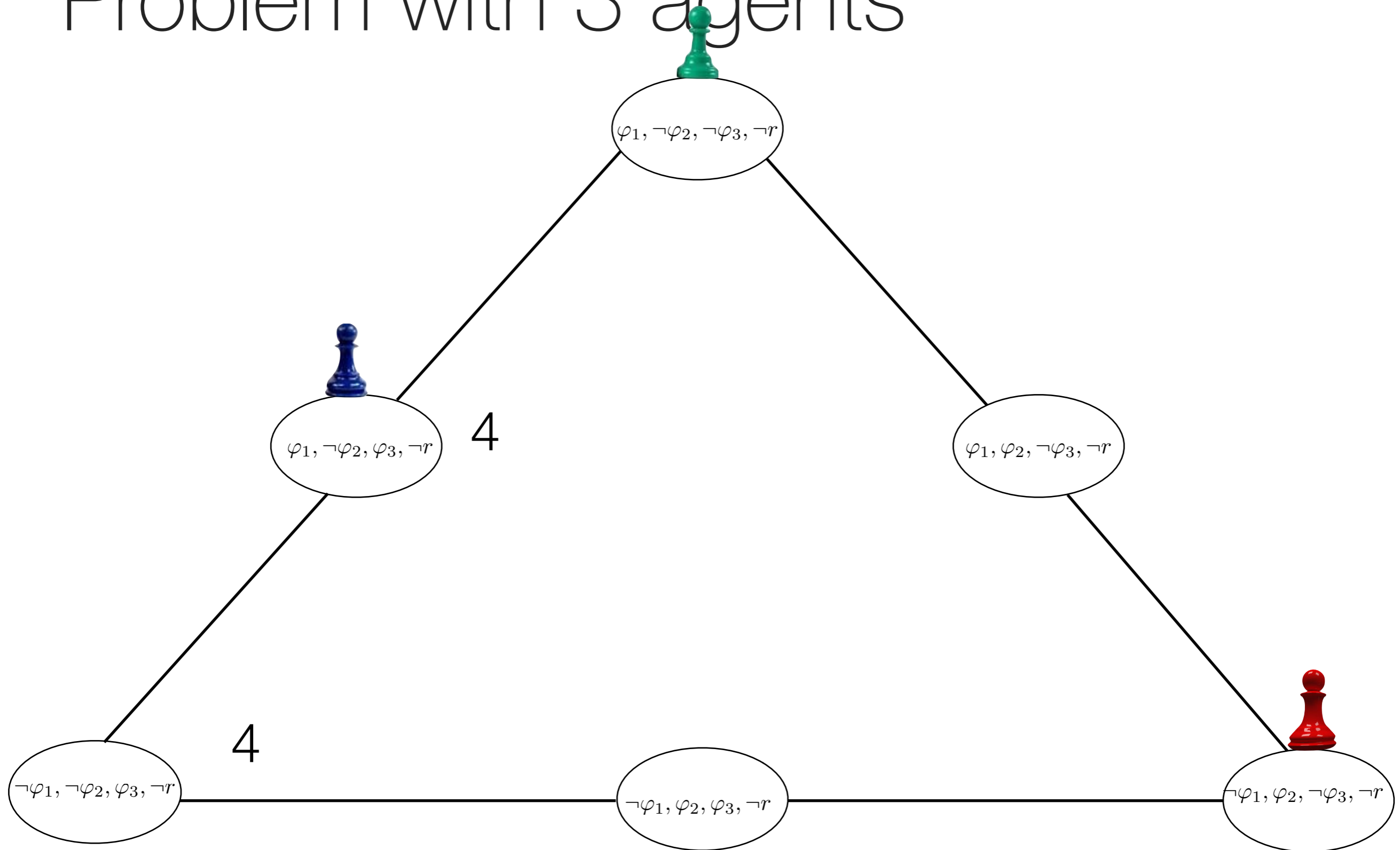

Problem with 3 agents

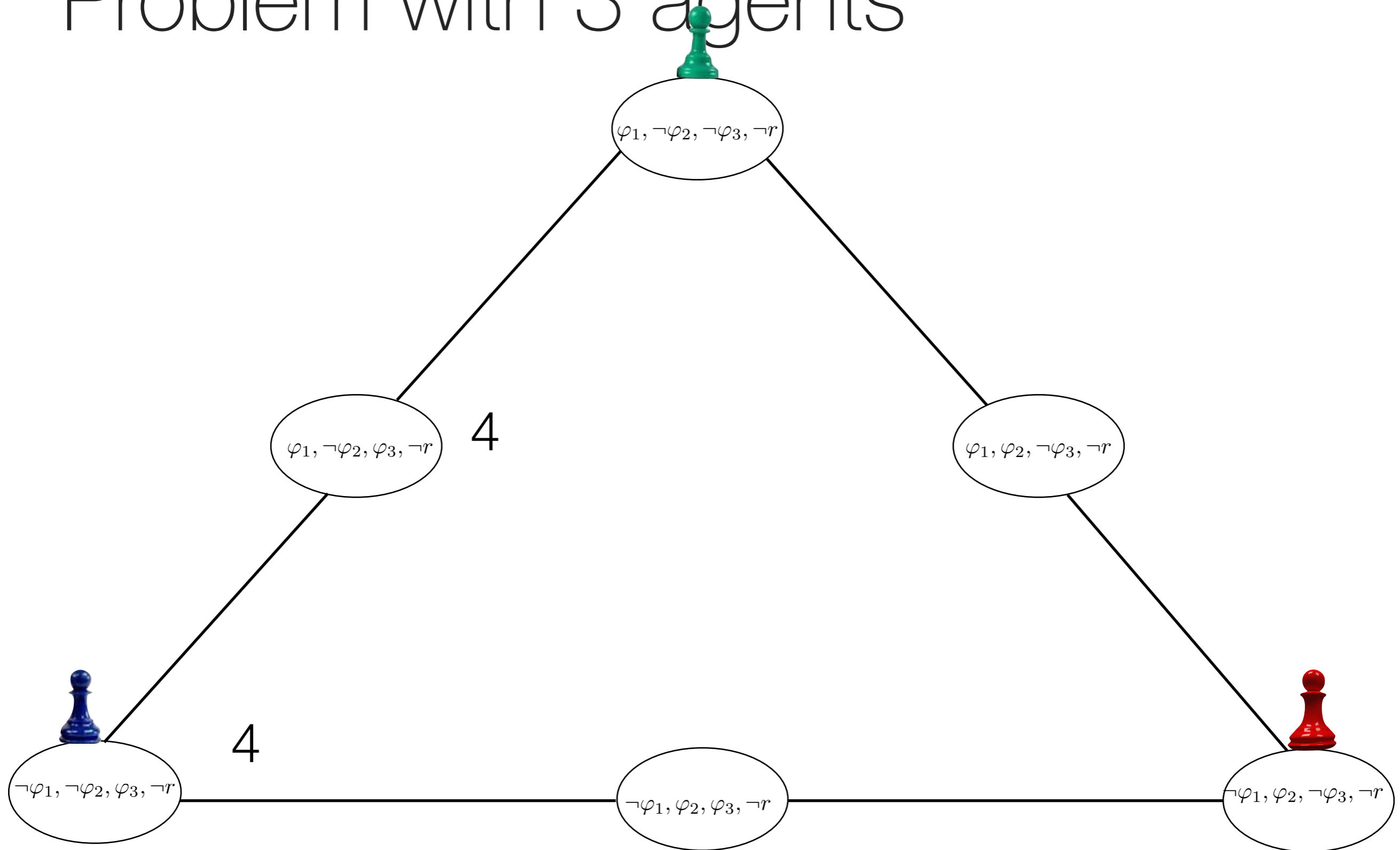

Problem with 3 agents

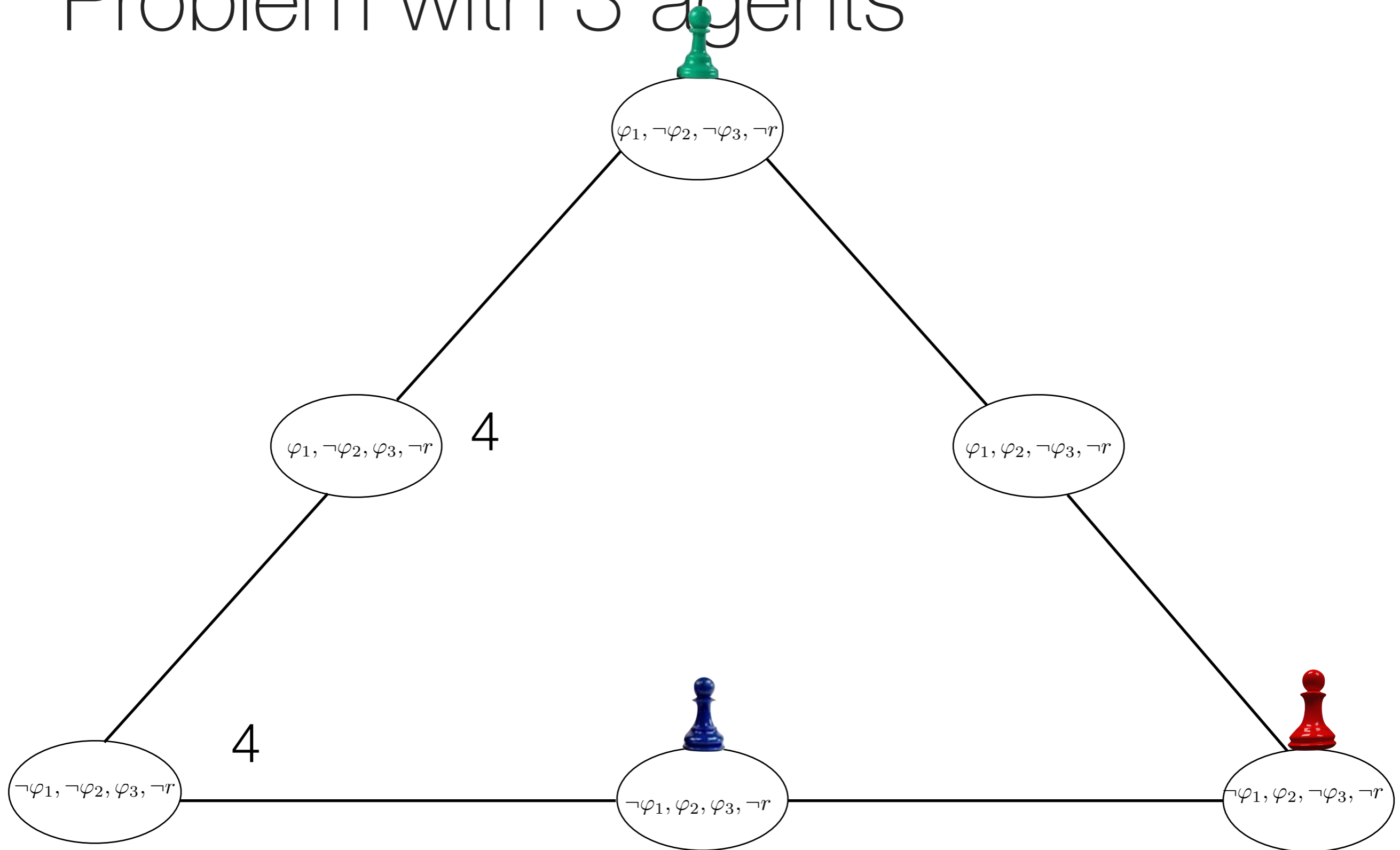

Problem with 3 agents

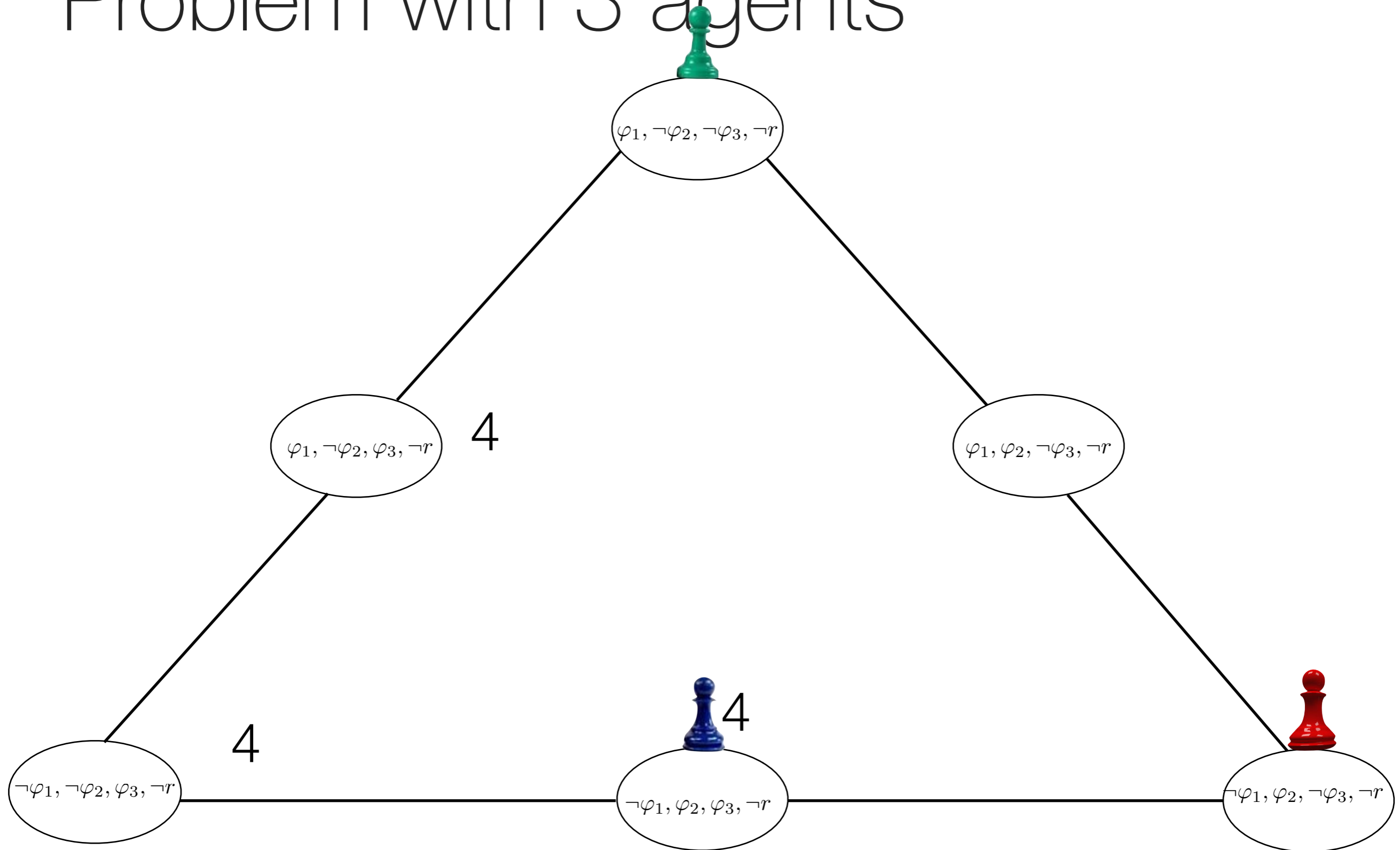

Problem with 3 agents

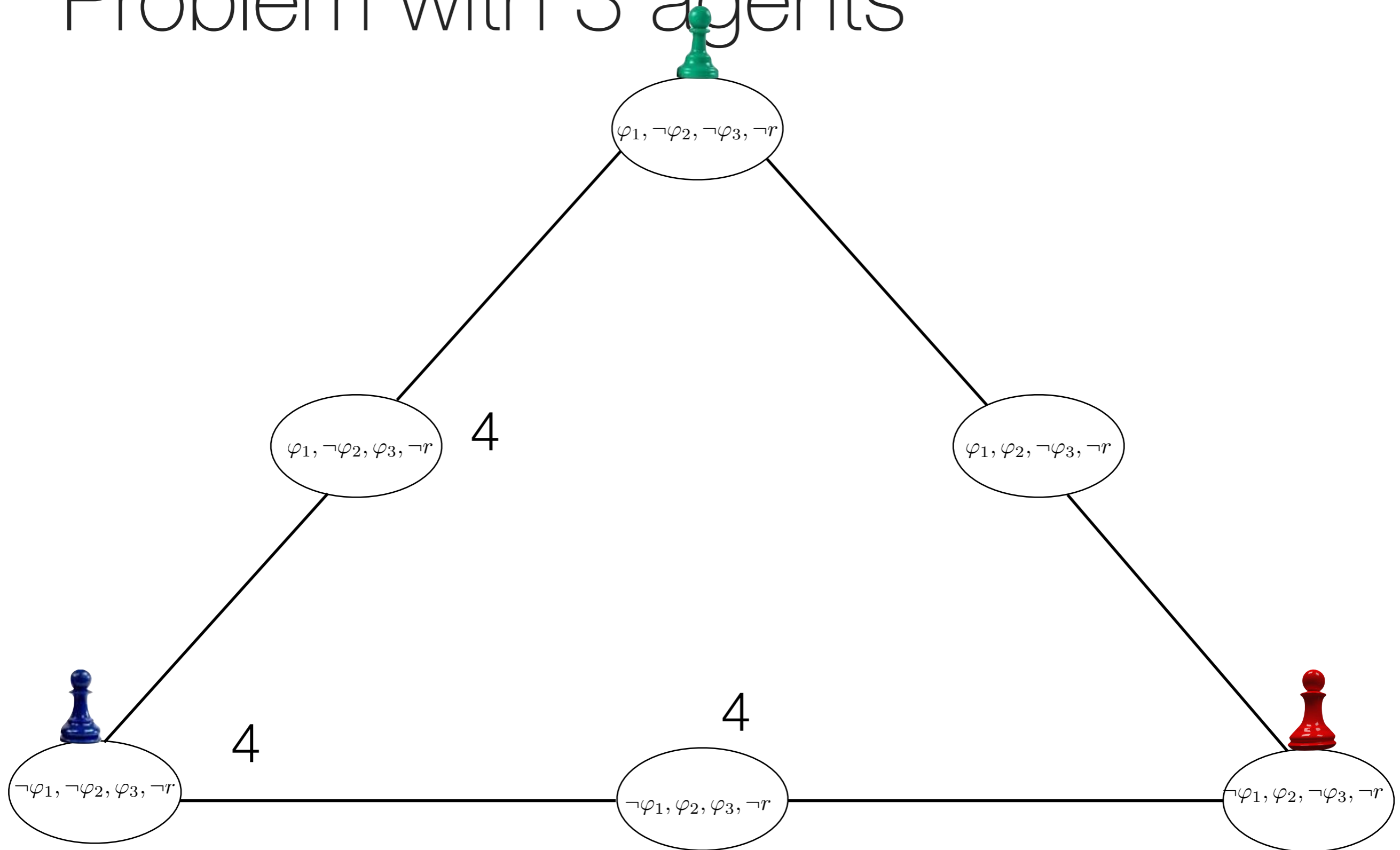

Problem with 3 agents

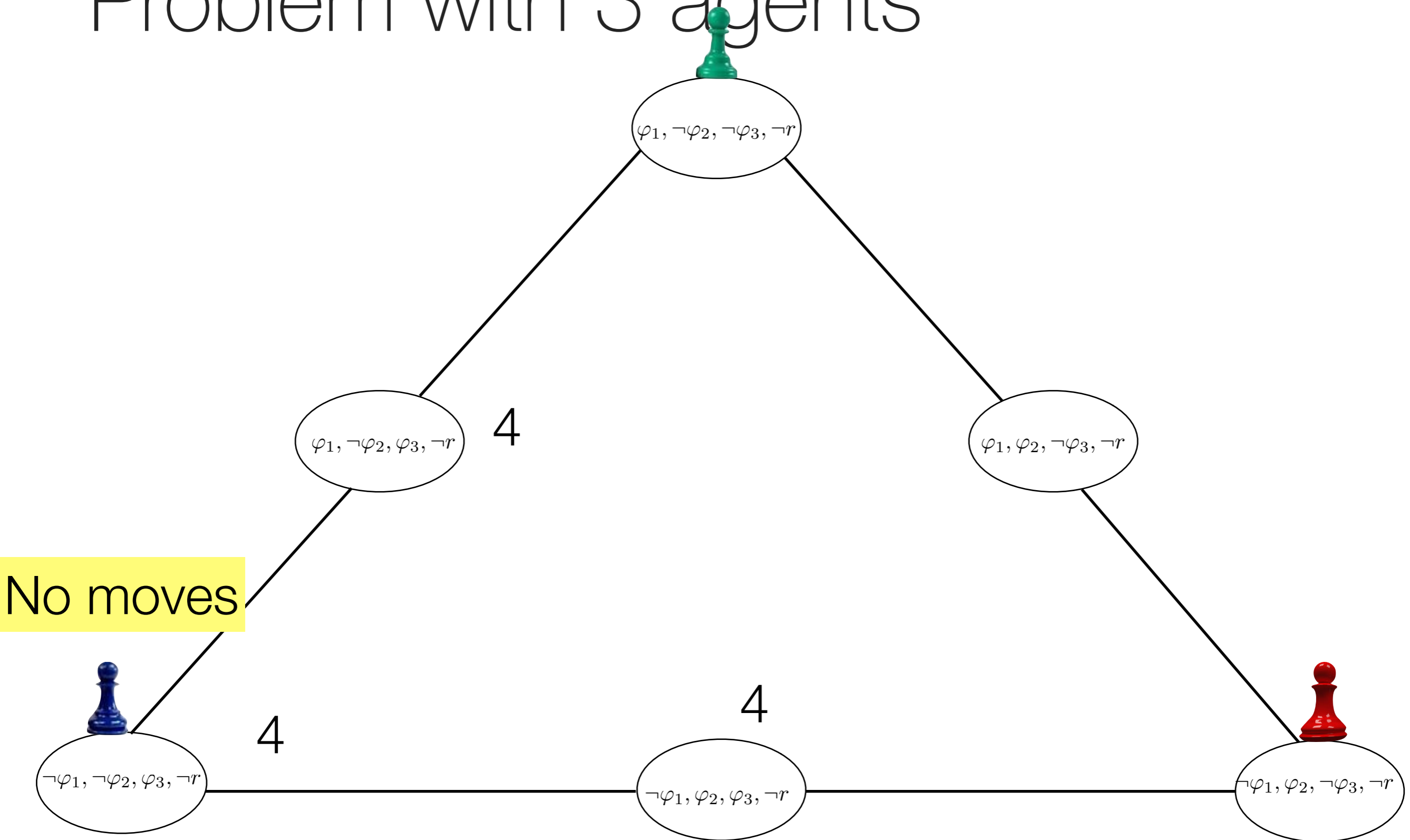

Good profile sub-graph shapes

So far:

- Trees, or
- No more than 2 edges per node

Complexity

Complexity

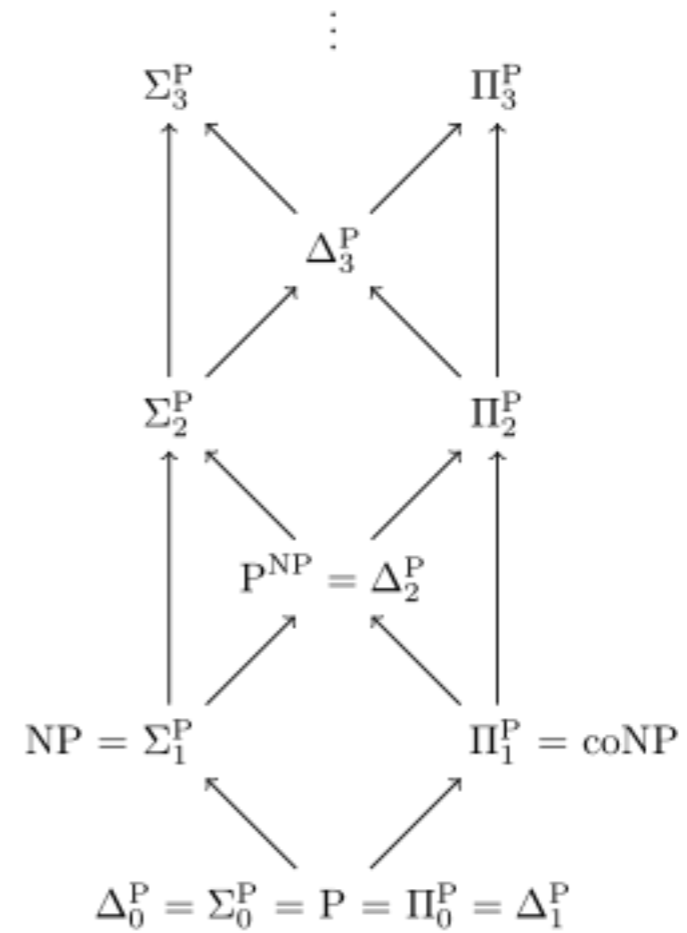

Complexity

Geodesic graph

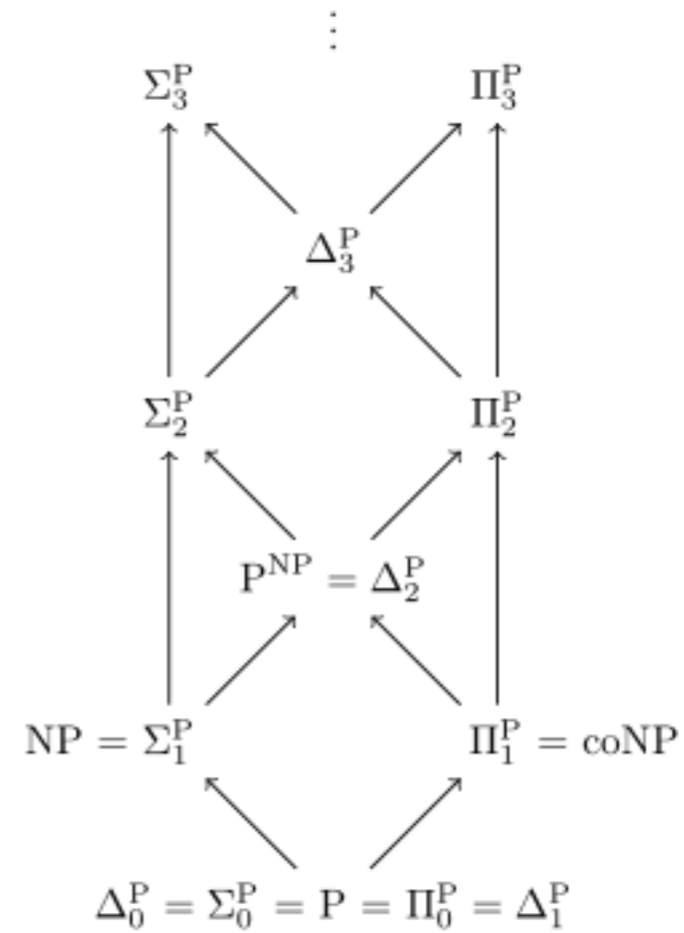

Complexity

Geodesic graph

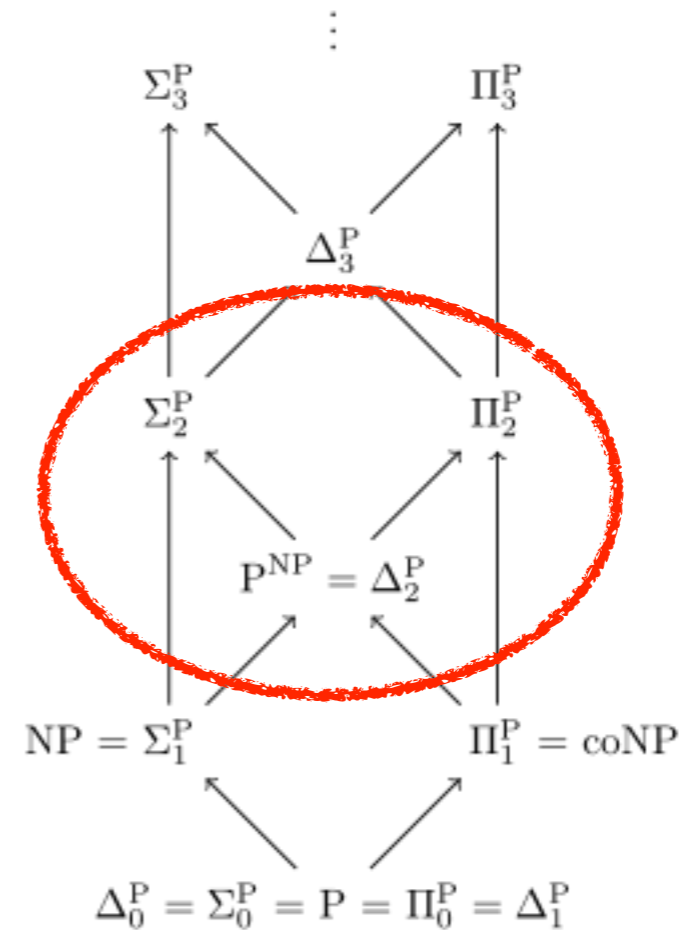

Complexity

Geodesic graph

Hamming graph

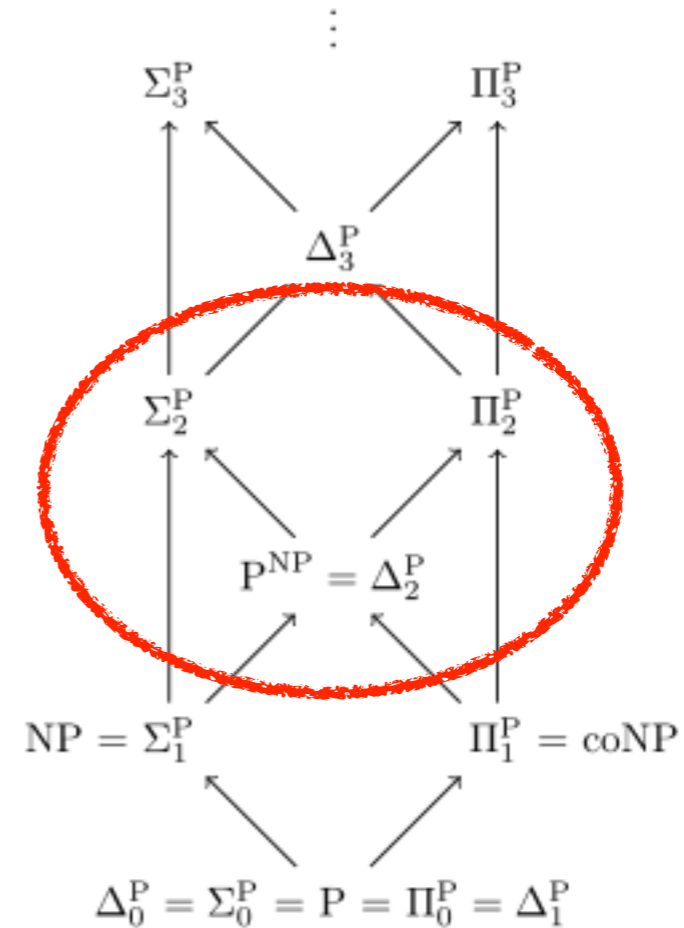

Complexity

Geodesic graph

Hamming graph

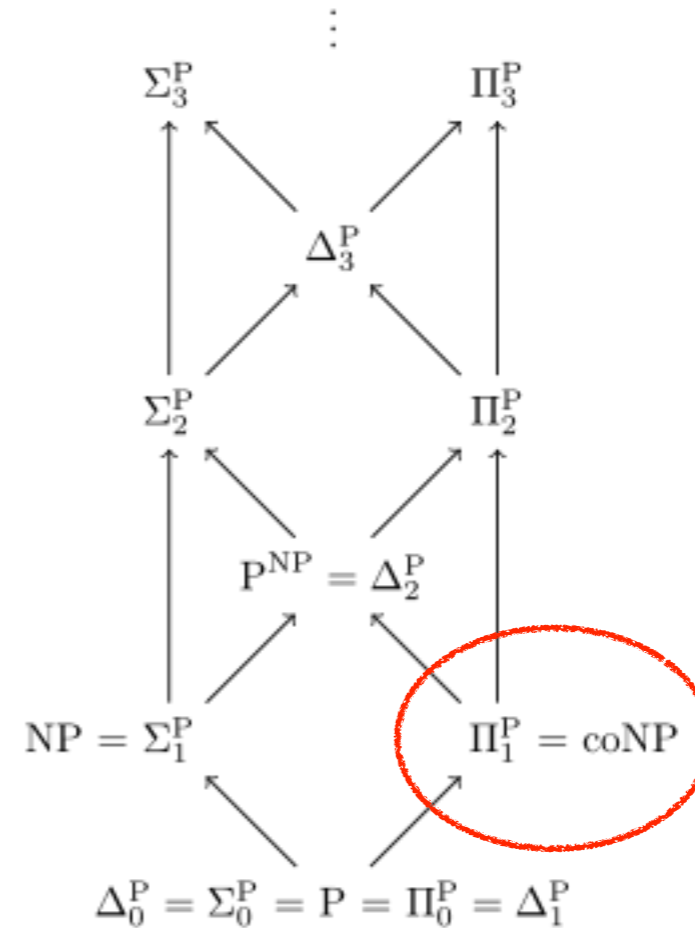

Future work

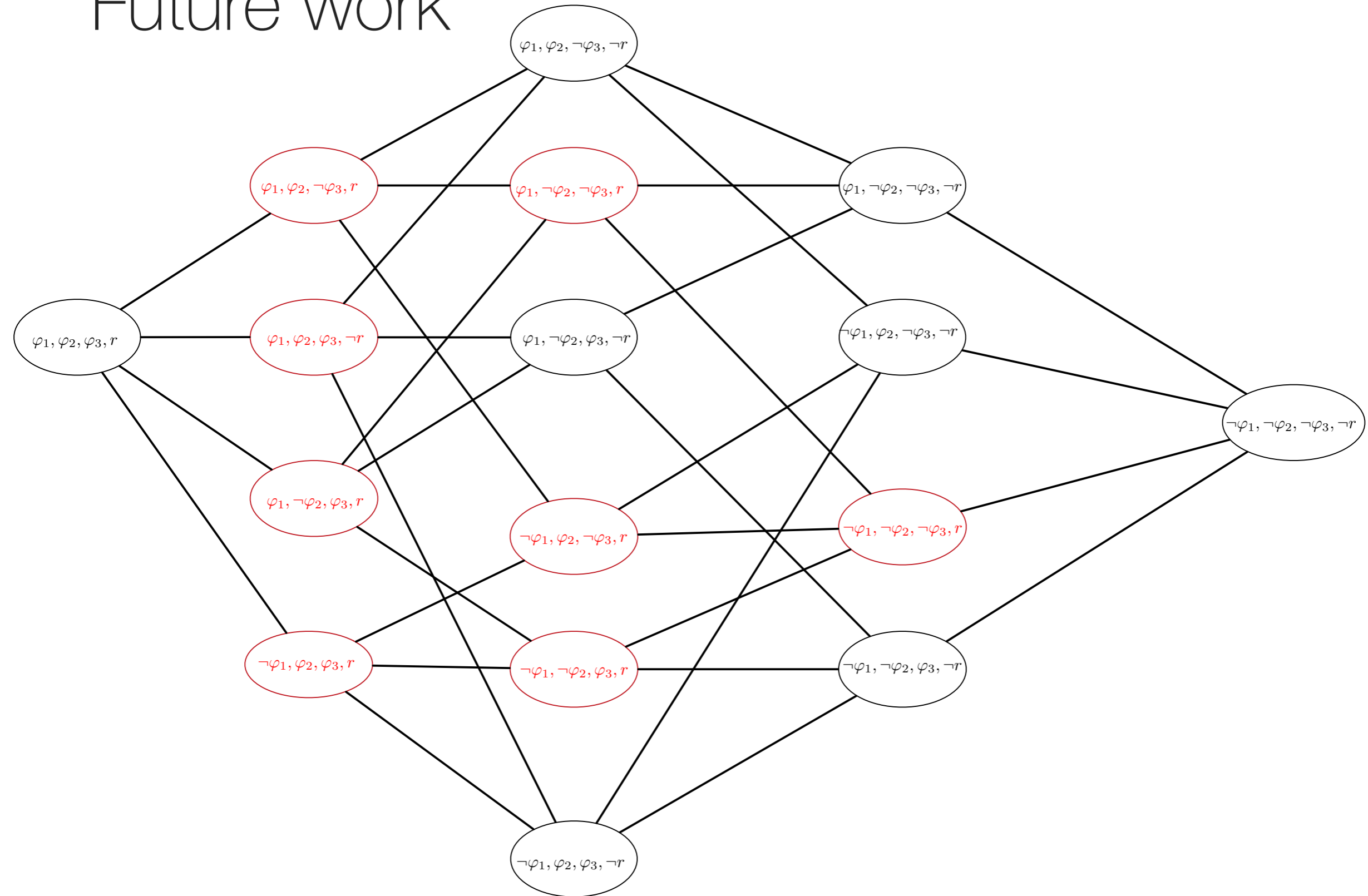

Future work

- Find all good shapes

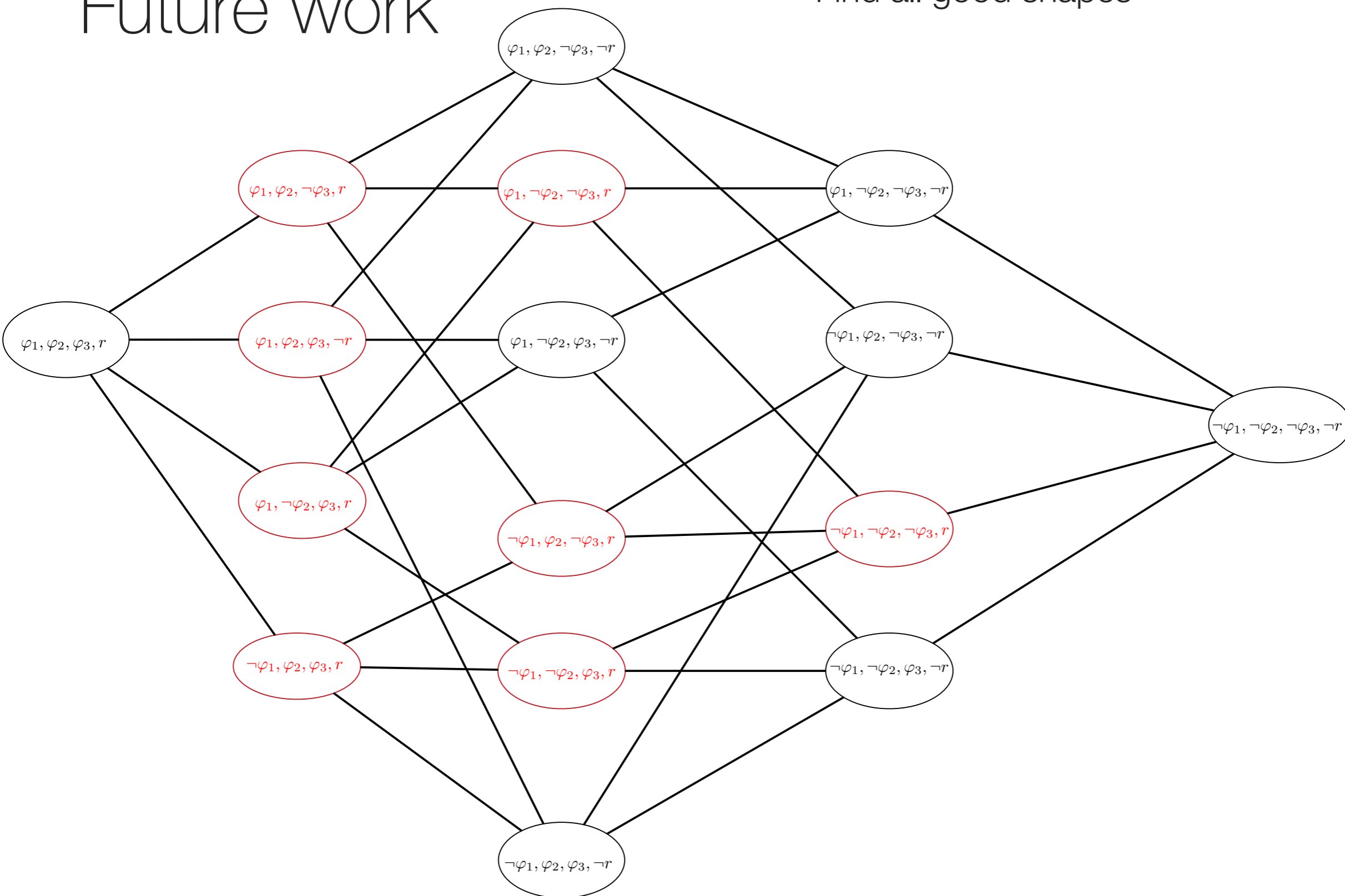

Future work

- Find all good shapes
- Extend algorithm to k-connected profiles

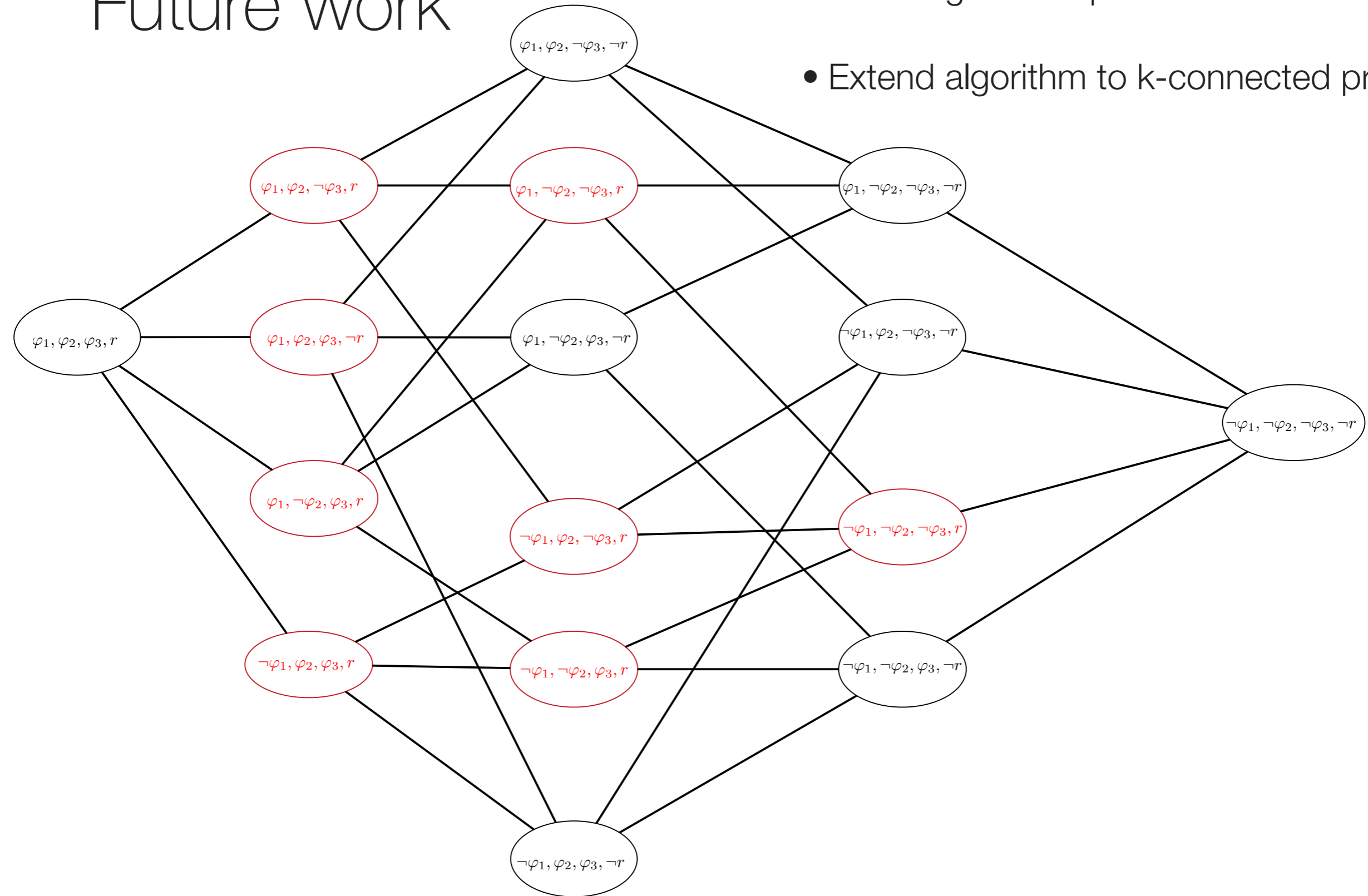

Future work

- Find all good shapes
- Extend algorithm to k-connected profiles

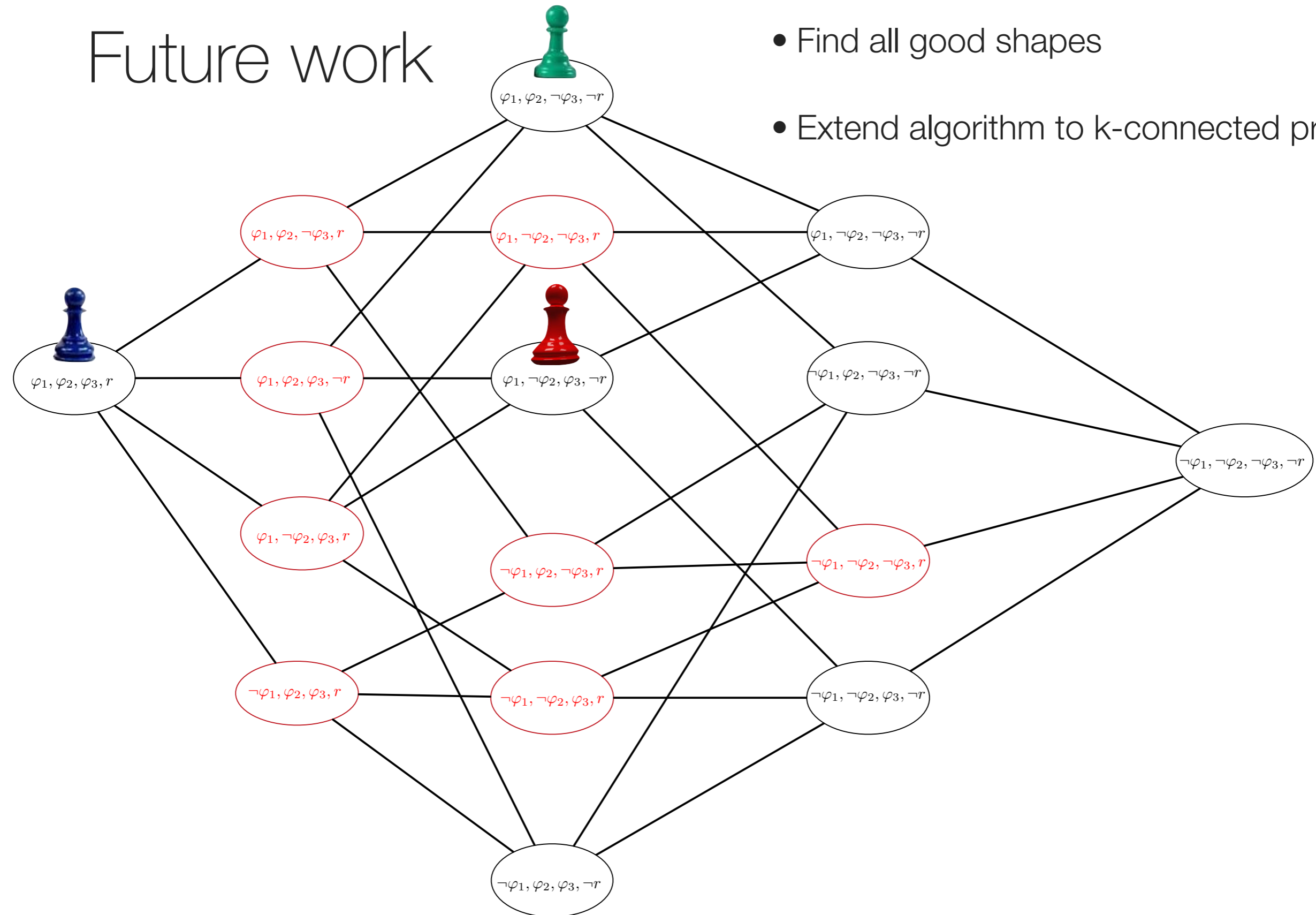

Future work

- Find all good shapes
- Extend algorithm to k-connected profiles
- Get closer to friends not to all

